

Installation/Anschluss
 Installation/Raccordement
 Installation/Connection

AB121L

- Sounder unit: Alarm horn sounder: 64 tones, 4 stages
- L.E.D Array Beacon
- 32 x High powered L.E.D's
- IP Rating: IP65
- 9 Selectable user modes
- 3 Stages on DC units only
- Temp: -25°C to + 50°C
- Unit weight: 3kg DC 3.3kg AC
- CE & UKCA
- 2-off M20 x 1.5 thread entries.

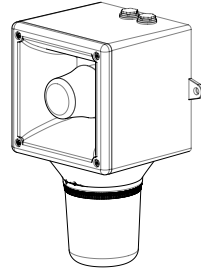

Unit Type Code	Nominal Voltage	Voltage Range	Nominal Current P2	Nominal Current P3	Nominal Beacon Current	Nominal SPL P2 / P3	Max SPL P2 / P3	Average SPL P2 / P3
AB121L.024.2	24VDC	10-50Vdc	430mA	930mA	400mA	116.9dB(A) / 120.2dB(A) Tone 44 @ 1m	120.7dB(A) / 123.4dB(A) Tone 4 @ 1m	115.3dB(A) / 118.1dB(A) All Tones @ 1m
AB121L.024.2	48VDC		223mA	453mA	400mA			
AB121L.115.7	115VAC	103.5- 126.5Vdc	173mA	340mA	140mA			
AB121L.230.7	230VAC	207-253Vdc 50/60Hz	105mA	212mA	70mA			

Supply voltage variation of +/-10% outside the voltage range is permissible
 Nominal current at nominal voltage

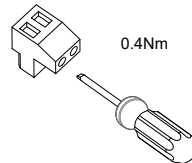
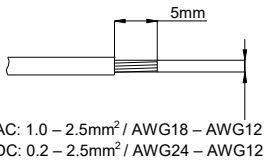

Attention: Installation must be carried out by an electrician in compliance with the latest codes and regulations.
 Attention: L'installation doit être effectuée par un électricien conformément aux derniers codes et réglementations.
 Achtung: Die Installation muss von einem Elektriker gemäß den neuesten Vorschriften und Bestimmungen durchgeführt werden.



Attention: Disconnect from power source before installation or service to prevent electric shock
 Attention: Débranchez-le de la source d'alimentation avant l'installation ou l'entretien pour éviter tout choc électrique.
 Achtung: Vor Installation oder Wartung von der Stromquelle trennen, um einen Stromschlag zu vermeiden.

INSTRUCTION & SERVICE MANUAL

AB121L

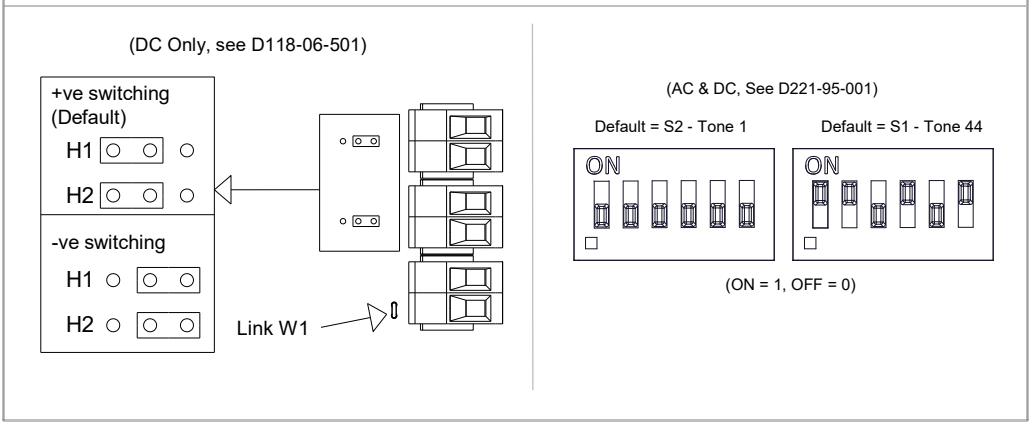
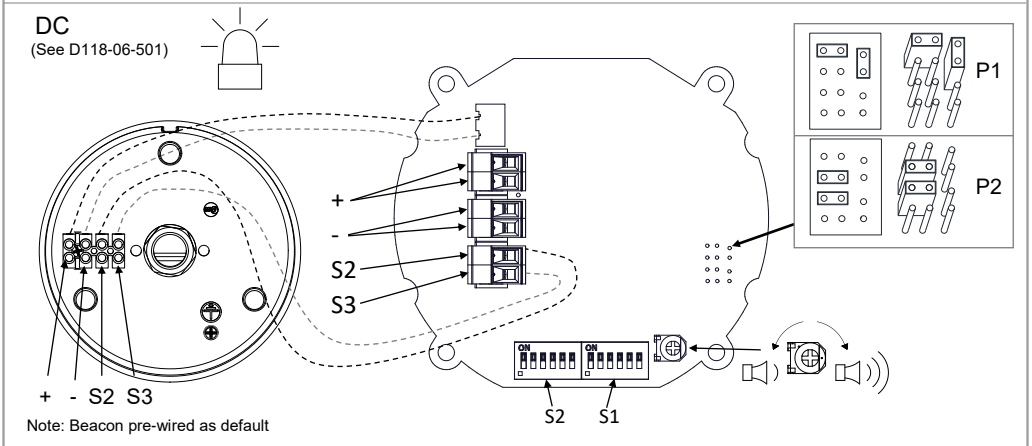
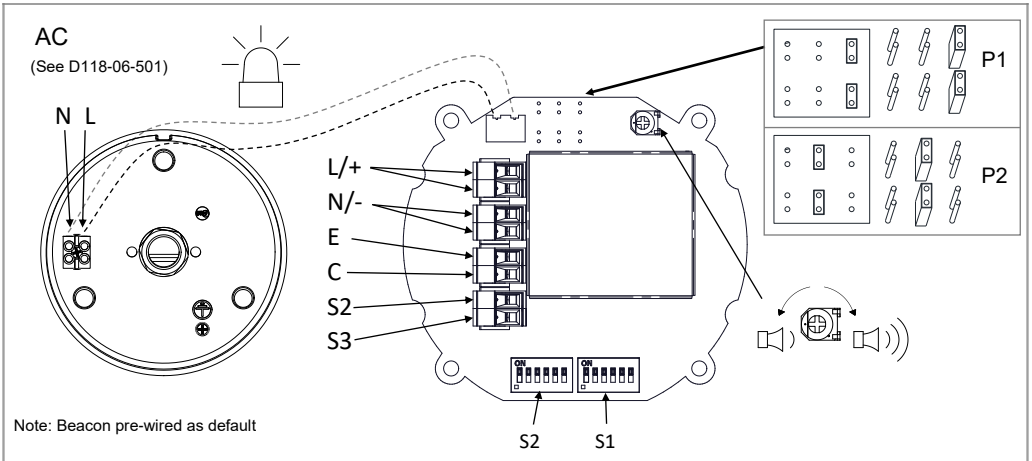

INSTRUCTION & SERVICE MANUAL
 AB121L

The Beacon lens cover is field replaceable.

To change the lens cover, rotate 1-off M4 pozi head screw clockwise, remove the existing lens by rotating the lens to align with the unlock markings as shown below. Replace the lens cover and rotate to the locked marking position. Rotate the 1-off M4 pozi head fastener anti-clockwise to secure the lens.

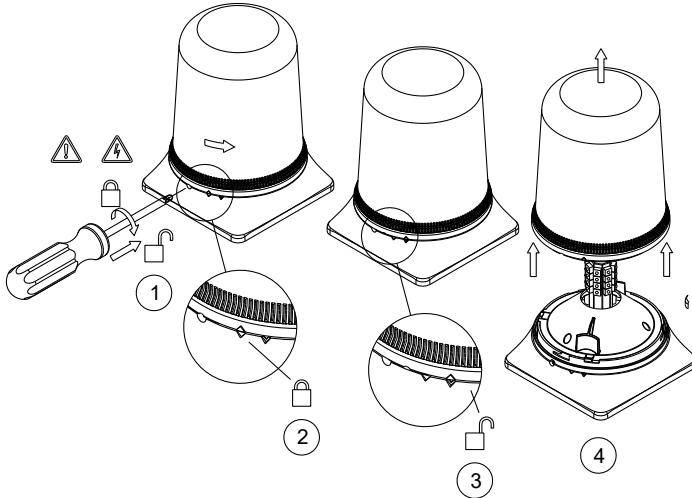

Attention: Lens on unit will be hot allow to cool prior to removal.

To access the beacon mode settings, remove the beacon lens following the steps above then remove the 3-off pozi head screws. Reinstall the beacon in the same orientation.

AB121L

L.E.D Array Option Setting Table

Default setting is 6

PCB EDGE	1	2	3	4	5	6	7	8	9
	○ ○ ○	○ ○ ○	○ ○ ○	□ ○ ○	□ ○ ○	□ ○ ○	□ ○ ○	□ ○ ○	□ ○ ○
	○ ○ ○	□ ○ ○	□ ○ ○	○ ○ ○	□ ○ ○	□ ○ ○	○ ○ ○	□ ○ ○	□ ○ ○

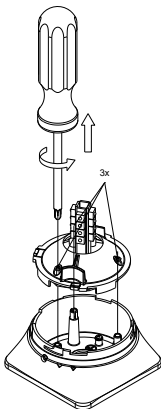

Stage 1	Frequency Description: Stage 1 (Ac & DC units)	Frequency Description: Stage 2 (DC unit only)	Frequency Description: Stage 3 (DC unit only)
1	All L.E.D's on	Alternate Side Flash 2Hz	Double Strike Flash 2Hz
2	Rotating: Slow 1	Alternate Side Flash 2Hz	All L.E.D's on
3	Single Strike Flash 2Hz	Rotating: Fast 2	All L.E.D's on
4	Rotating: Fast 1	Single Strike Flash 2Hz	All L.E.D's on
5	Rotating: Slow 2	Double Strike Flash 1Hz	All L.E.D's on
6	Double Strike Flash 2Hz	Rotating: Fast 2	All L.E.D's on
7	Rotating: Fast 2	Double Strike Flash 2Hz	All L.E.D's on
8	Double Strike Flash 1Hz	Alternate Side Flash 2Hz	All L.E.D's on
9	Alternate Side Flash 2Hz	Rotating: Fast 2	All L.E.D's on

INSTRUCTION & SERVICE MANUAL
AB121L

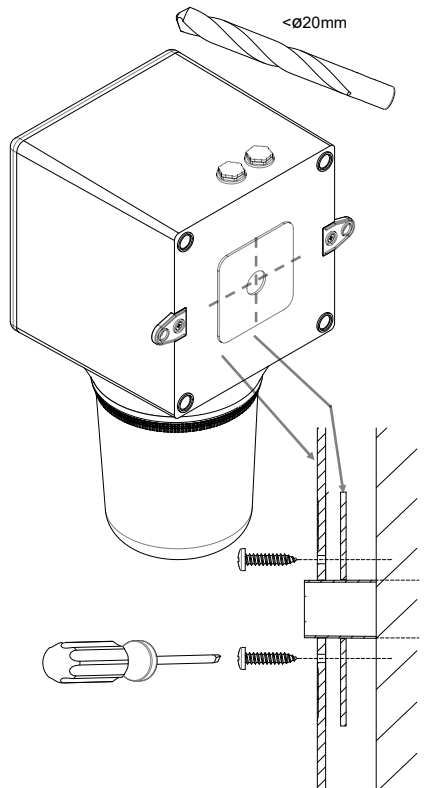
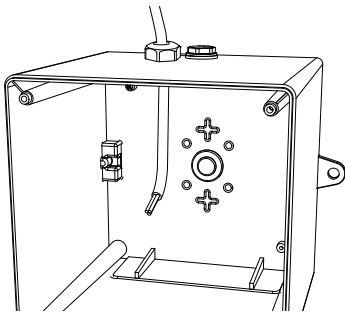
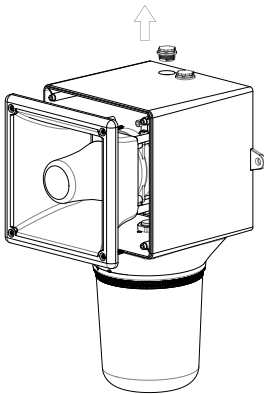
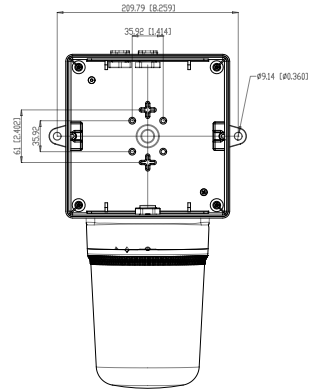
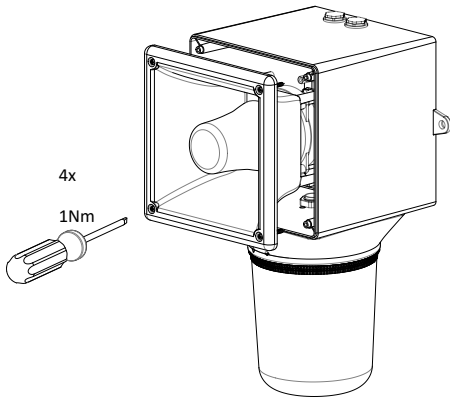

If a high IP (Ingress Protection) rating is required then a suitable sealing washer must be fitted under the cable glands or blanking plugs.

Stage 1 Set DIP SW 1 Tone No.	Tone Description	Tone Visual	Stage 1 & 2 DIP SW 1/2 Settings 1 2 3 4 5 6	Stage 3 Set DIP SW 1 (S3)	Stage 4 Set DIP SW 1 (S2 + S3)
1	1000Hz PFEER Toxic Gas		0 0 0 0 0	2	44
2	1200/500Hz @ 1Hz DIN /PFEER P.T.A.P.		1 0 0 0 0	3	44
3	1000Hz @ 0.5Hz(1s on, 1soff) PFEER Gen. Alarm		0 1 0 0 0	2	44
4	1.4KHz-1.6KHz 1s, 1.6KHz-1.4KHz 0.5s NF C 48-265		1 1 0 0 0	24	1
5	544Hz(100mS)/440Hz (400mS) NF S 32-001		0 0 1 0 0	19	1
6	1500/500Hz - (0.5s on , 0.5s off) x3 + 1s gap AS4428		1 0 1 0 0	44	1
7	500-1500Hz Sweeping 2 sec on 1 sec off AS4428		0 1 1 0 0	44	1
8	500/1200Hz @ 0.26Hz (3.3son, 0.5s off) Netherlands - NEN 2575		1 1 1 0 0	24	35
9	1000Hz (1s on, 1s off)x7 + (7s on, 1s off) IMO Code 1a		0 0 0 1 0	34	1
10	1000Hz (1s on, 1s off)x7 + (7s on, 1s off) IMO Code 1a		1 0 0 1 0	34	1
11	420Hz(0.5s on, 0.5s off)x3 + 1s gap ISO 8201 Temporal Pattern		0 1 0 1 0	1	8
12	1000Hz(0.5s on, 0.5s off)x3 + 1s gap ISO 8201 Temporal Pattern		1 1 0 1 0	1	8
13	422/775Hz - (0.85 on, 0.5 off) x3 + 1s gap NFPA - Temporal Coded		0 0 1 1 0	1	8
14	1000/2000Hz @ 1Hz Singapore		1 0 1 1 0	3	35
15	300Hz Continuous (f=300)		0 1 1 1 0	24	1
16	440Hz Continuous (f=440)		1 1 1 1 0	24	1
17	470Hz Continuous (f=470)		0 0 0 0 1	24	8
18	500Hz Continuous IMO code 2 (Low) (f=500)		1 0 0 0 1	24	8
19	554Hz Continuous (f=554)		0 1 0 0 1	24	8
20	660Hz Continuous (f=660)		1 1 0 0 1	24	35
21	800Hz IMO code 2 (High) (f=800)		0 0 1 0 1	24	35
22	1200Hz Continuous (f=1200)		1 0 1 0 1	24	35
23	2000Hz Continuous (f=2000)		0 1 1 0 1	3	35
24	2400Hz Continuous (f=2400)		1 1 1 0 1	20	35
25	440Hz @0.83Hz (50 cycles/minute) Intermittent (f=440, a=0.6, b=0.6)		0 0 0 1 1	44	8
26	470Hz @0.9Hz - 1.1s Intermittent (f=470, a=0.55, b=0.55)		1 0 0 1 1	44	8
27	470Hz @5Hz - (5 cycles/second) Intermittent (f=470, a=0.1, b=0.1)		0 1 0 1 1	44	8
28	544Hz @ 1.14Hz - 0.875s Intermittent (f=470, a=0.43, b=0.44)		1 1 0 1 1	24	8
29	655Hz @ 0.875Hz Intermittent (f=655, a=0.57, b=0.57)		0 0 1 1 1	24	8
30	660Hz @0.28Hz - 1.8sec on, 1.8sec off Intermittent (f=660, a=1.8, b=1.8)		1 0 1 1 1	24	8
31	660Hz @3.34Hz - 150mS on, 150mS off Intermittent (f=660, a=0.15, b=0.15)		0 1 1 1 1	24	8
32	745Hz @ 1Hz Intermittent (f=745, a=0.5, b=0.5)		1 1 1 1 1	24	8
33	800Hz - 0.25sec on, 1 sec off Intermittent (f=800, a=0.25, b=1)		0 0 0 0 1	24	8
34	800Hz @ 2Hz IMO code 3.a (High) Intermittent (f=800, a=0.25, b=0.25)		1 0 0 0 1	24	19
35	1000Hz @ 1Hz Intermittent (f=1000, a=0.5, b=0.5)		0 1 0 0 1	24	19
36	2400Hz @ 1Hz Intermittent (f=2400, a=0.5, b=0.5)		1 1 0 0 1	24	19
37	2900Hz @ 5Hz Intermittent (f=2900, a=0.1, b=0.1)		0 0 1 0 1	24	19
38	363/518Hz @ 1Hz Alternating (f=363, f1=518, a=0.1)		1 0 1 0 1	8	19
39	450/500Hz @ 2Hz Alternating (f=450, f1=500, a=0.25)		0 1 1 0 1	8	19
40	554/440Hz @ 1Hz Alternating (f=440, f1=554, a=0.5)		1 1 1 0 1	24	19
41	554/440Hz @ 0.625Hz Alternating (f=440, f1=554, a=0.8)		0 0 0 1 1	8	19
42	561/760Hz @0.83Hz (50 cycles/minute) Alternating (f=561, f1=760, a=0.6)		1 0 0 1 1	8	19
43	780/600Hz @ 0.96Hz Alternating (f=600, f1=780, a=0.52)		0 1 0 1 1	8	19
44	800/1000Hz @ 2Hz Alternating (f=800, f1=1000, a=0.25)		1 1 0 1 1	24	19
45	970/800Hz @ 2Hz Alternating (f=800, f1=970, a=0.25)		0 0 1 1 1	8	19
46	800/1000Hz @ 0.875Hz Alternating (f=800, f1=1000, a=0.57)		1 0 1 1 1	24	19
47	2400/2900Hz @ 2Hz Alternating (f=2400, f1=2900, a=0.25)		0 1 1 1 1	24	19
48	500/1200Hz @ 0.3Hz Sweeping (f=500, f1=1200, a=3.34)		1 1 1 1 1	24	12
49	560/1055Hz @ 0.18Hz Sweeping (f=560, f1=1055, a=5.47)		0 0 0 1 1	24	12
50	560/1055Hz @ 3.3Hz Sweeping (f=560, f1=1055, a=0.3)		1 0 0 1 1	24	12
51	600/1250Hz @ 0.125Hz Sweeping (f=600, f1=1250, a=8)		0 1 0 0 1	24	12
52	660/1200Hz @ 1Hz Sweeping (f=660, f1=1200, a=1)		1 1 0 0 1	24	12
53	800/1000Hz @ 1Hz Sweeping (f=800, f1=1000, a=1)		0 0 1 0 1	24	12
54	800/1000Hz @ 7Hz Sweeping (f=800, f1=1000, a=0.14)		1 0 1 0 1	24	12
55	800/1000Hz @ 50Hz Sweeping (f=800, f1=1000, a=0.02)		0 1 1 0 1	24	12
56	2400/2900Hz @ 7Hz Sweeping (f=2400, f1=2900, a=0.14)		1 1 1 0 1	24	12
57	2400/2900Hz @ 1Hz Sweeping (f=2400, f1=2900, a=1)		0 0 1 1 1	24	12
58	2400/2900Hz @ 50Hz Sweeping (f=2400, f1=2900, a=0.02)		1 0 0 1 1	24	12
59	2500/3000Hz @ 2Hz Sweeping (f=2500, f1=3000, a=0.5)		0 1 0 1 1	24	12
60	2500/3000Hz @ 7.7Hz Sweeping (f=2500, f1=3000, a=0.13)		1 1 0 1 1	24	12
61	800Hz Motor Siren (f=800, a=1.6)		0 0 1 1 1	24	12
62	1200Hz Motor Siren (f=1200, a=2)		1 0 1 1 1	24	12
63	2400Hz Motor Siren (f=2400, a=1.7)		0 1 1 1 1	24	12
64	Simulated Bell		1 1 1 1 1	21	12

1	2	3	4	5	6	7	8	9	10
							ISSUE	MOD No.	REASON - INITIAL - DATE
							A		INTRODUCTION JS- 28/06/2021

— — WIRING LINKING BEACON & SOUNDER
FACTORY FITTED

OPTIONAL LINE MONITORING RESISTOR, CUSTOMER SUPPLIED,
RECOMMENDED MINIMUM VALUES:
14V MAX SYSTEM = 120Ω MIN, 2W MIN OR 1KΩ MIN, 0.5W MIN
28V MAX SYSTEM = 470Ω MIN, 2W MIN OR 2.4KΩ MIN, 0.5W MIN

Linked Sounder & Beacon Activation (Default)

Single Stage Configuration	Config.: 1a	Two Stage Configuration	Config.: 1b	Three/Four Stage Configuration	Config.: 1c
Line Monitoring Set to positive switching (default)		Common Negative Set to positive switching (default)		Common Negative Set to positive switching (default)	
Stage 1: Apply Power to Stage 1 +ve & Stage 1 -ve		Stage 1: Apply Power to Stage 1 +ve & Common -ve Stage 2: Apply Power to Stage 2 +ve & Common -ve		Stage 1: Apply Power to Stage 1 +ve & Common -ve Stage 2: Apply Power to Stage 2 +ve & Common -ve Stage 3: Apply Power to Stage 3 +ve & Common -ve Stage 4: Apply Power to Stage 2 +ve, Stage 3 +ve & Common -ve	

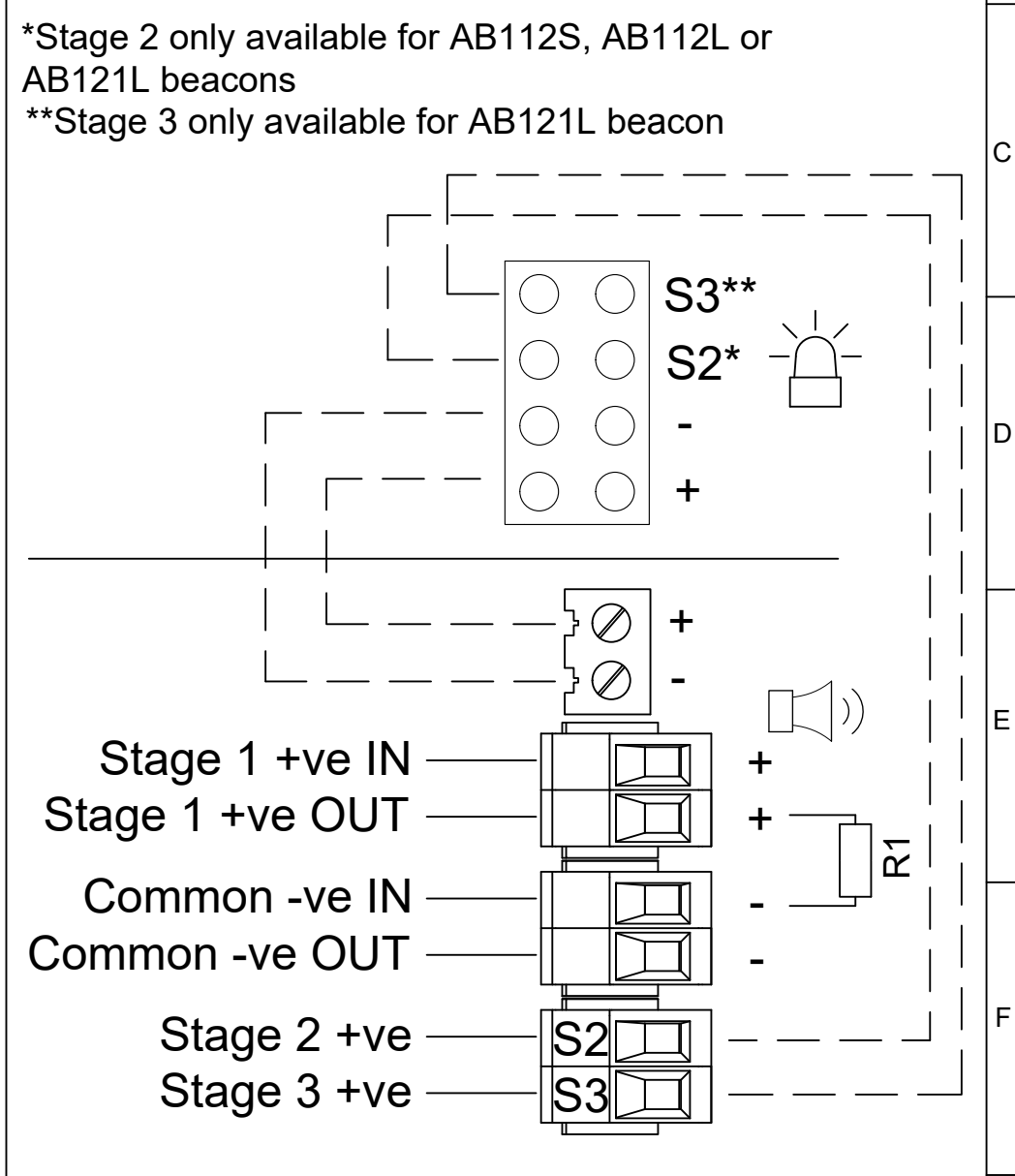
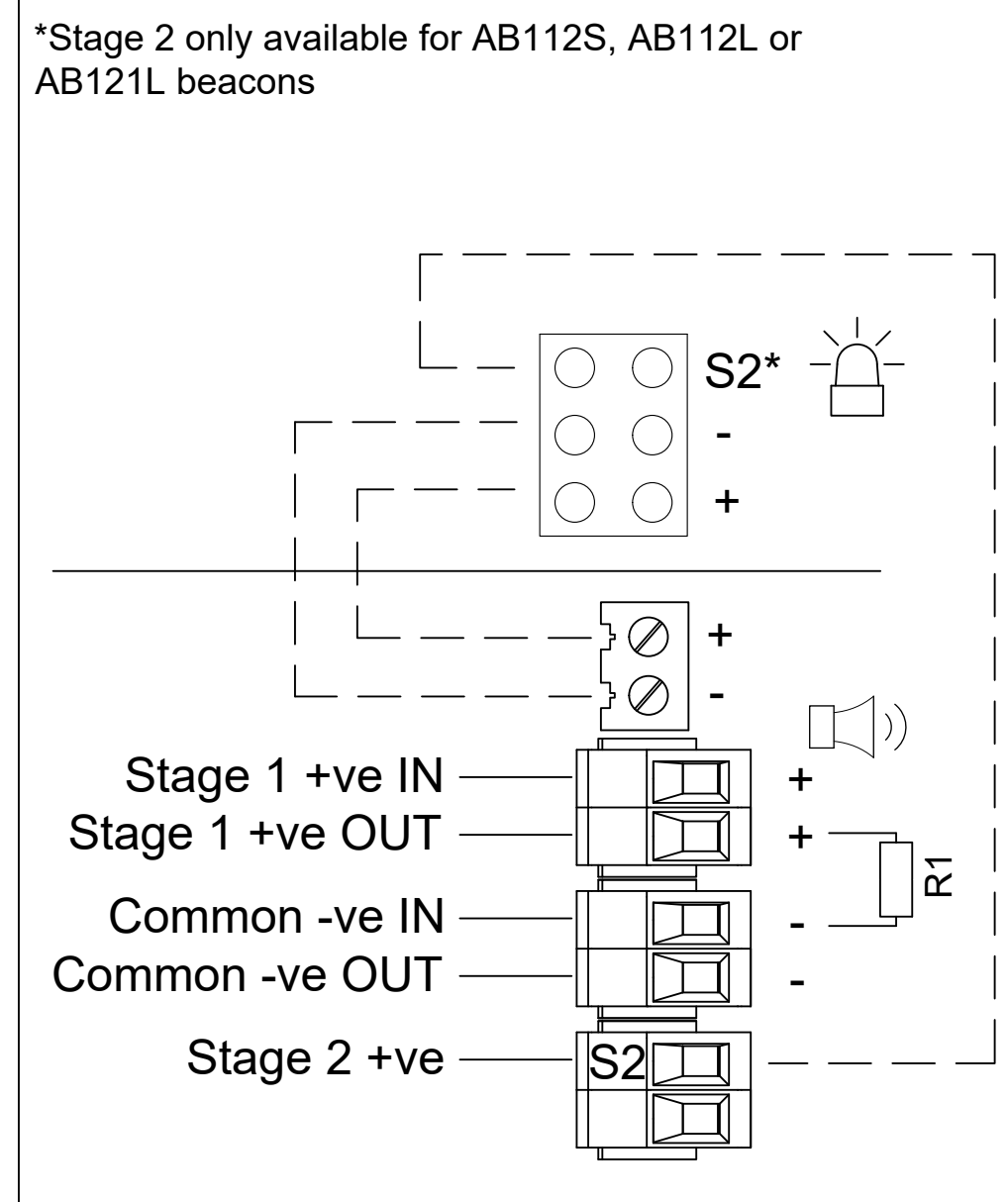
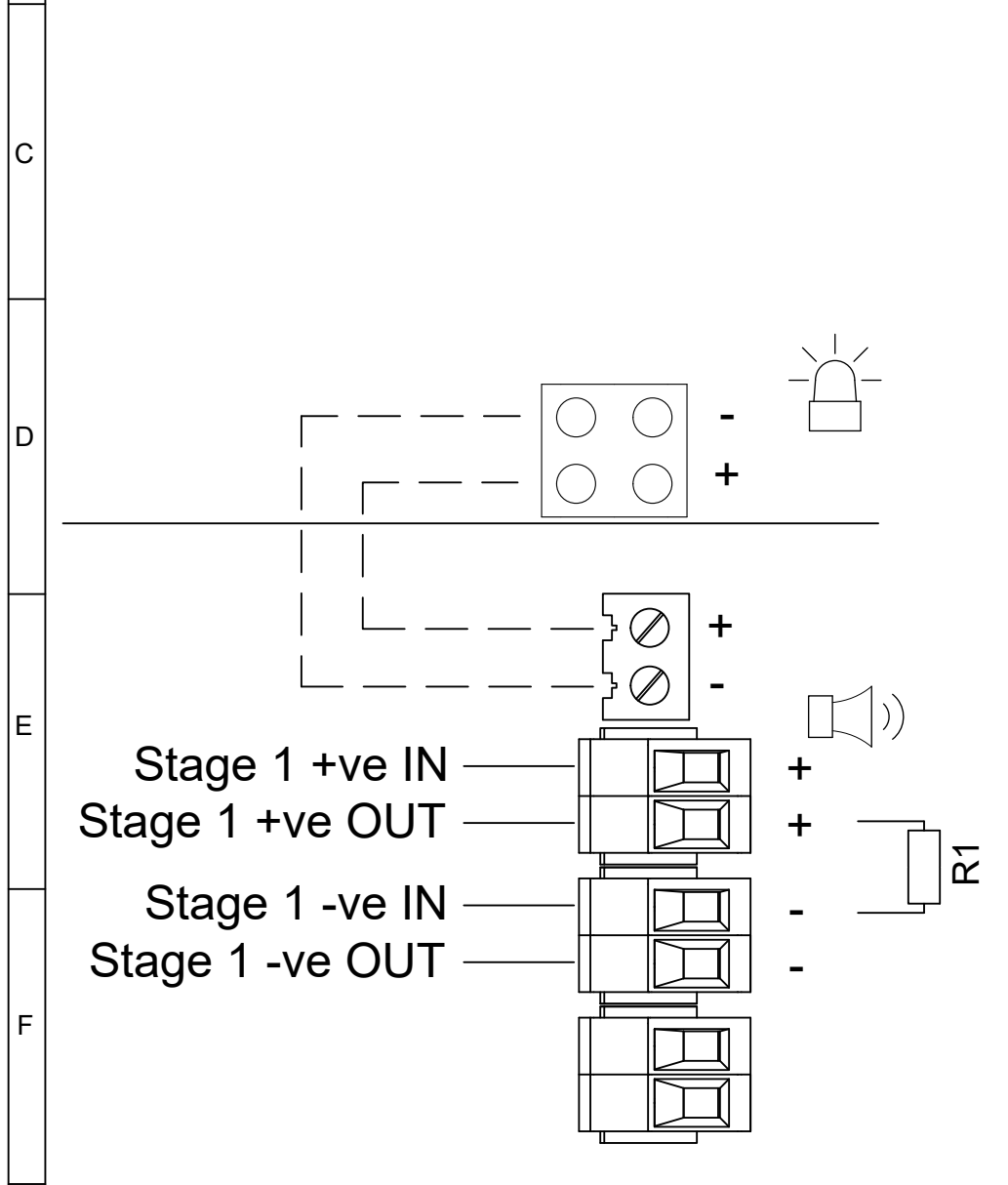

DRAWING TO BS8888:2000 GEOMETRIC TOLERANCES TO ISO1101:1983 LINEAR DIMENSIONAL TOLS ANGULAR DIMENSIONAL TOLS	DRAWN	DATE	SURFACE FINISH	WEIGHT (Kg)	THIS DRAWING AND ANY INFORMATION OR DESCRIPTIVE MATTER THEREIN IS COMMUNICATED IN CONFIDENCE AND IS THE COPYRIGHT PROPERTY OF EUROPEAN SAFETY SYSTEMS LTD. NEITHER THE WHOLE OR ANY EXTRACT MAY BE DISCLOSED, LOANED, COPIED OR USED FOR MANUFACTURING OR TENDERING PURPOSES WITHOUT THEIR WRITTEN CONSENT.	ALL DIMENSIONS IN MM IF IN DOUBT, ASK - DO NOT SCALE		A3
	J.SPILLER	28/06/2021						
	CHECKED	DATE						
	B.ISARD	28/06/2021						
STANDARDS	APPROVED	DATE	ALTERNATIVE MATERIAL			TITLE		
SPECTRALARM RANGE	R.N.POTTS	28/06/2021				AB112/AB121 COMBINED SOUNDER & BEACON WIRING DIAGRAMS		
						SCALE	SHEET	DRAWING NUMBER
						NTS	1 OF 8	D118-06-501

ISSUE	MOD No.	REASON - INITIAL - DATE
A		INTRODUCTION JS- 28/06/2021

— — WIRING LINKING BEACON & SOUNDER
FACTORY FITTED

OPTIONAL LINE MONITORING RESISTOR, CUSTOMER SUPPLIED,
RECOMMENDED MINIMUM VALUES:
14V MAX SYSTEM = 120Ω MIN, 2W MIN OR 1KΩ MIN, 0.5W MIN
28V MAX SYSTEM = 470Ω MIN, 2W MIN OR 2.4KΩ MIN, 0.5W MIN

SWITCHES FOR STAGE OPERATION
CUSTOMER SUPPLIED

Linked Sounder & Beacon Activation (Default)

Three/Four Stages. Voltage Free 2nd, 3rd & 4th Stage Activation Configuration Config.: 2 Two Stage Configuration Config.: 3

Common Positive
Customer Set H1 & H2 to Negative Switching (See Below)

Independent Stage Input
Reverse Polarity Stage Monitoring

Stage 1: Apply Power to Common +ve & Stage 1 -ve
Stage 2: Apply Power to Common +ve & Stage 1 -ve & connect Stage 2 -ve to Stage 1 -ve
Stage 3: Apply Power to Common +ve & Stage 1 -ve & connect Stage 3 -ve to Stage 1 -ve
Stage 4: Apply Power to Common +ve & Stage 1 -ve
& connect Stage 2 -ve & Stage 3 -ve to Stage 1 -ve

Stage 1: Apply Power to Stage 1 +ve & Stage 1 -ve
Stage 2: Apply Power to Stage 1 +ve & Stage 1 -ve & connect Stage 2 -ve to Stage 1 -ve

*Stage 2 only available for AB112S, AB112L or AB121L beacons

*Stage 2 only available for AB112S, AB112L or AB121L beacons

**Stage 3 only available for AB121L beacon

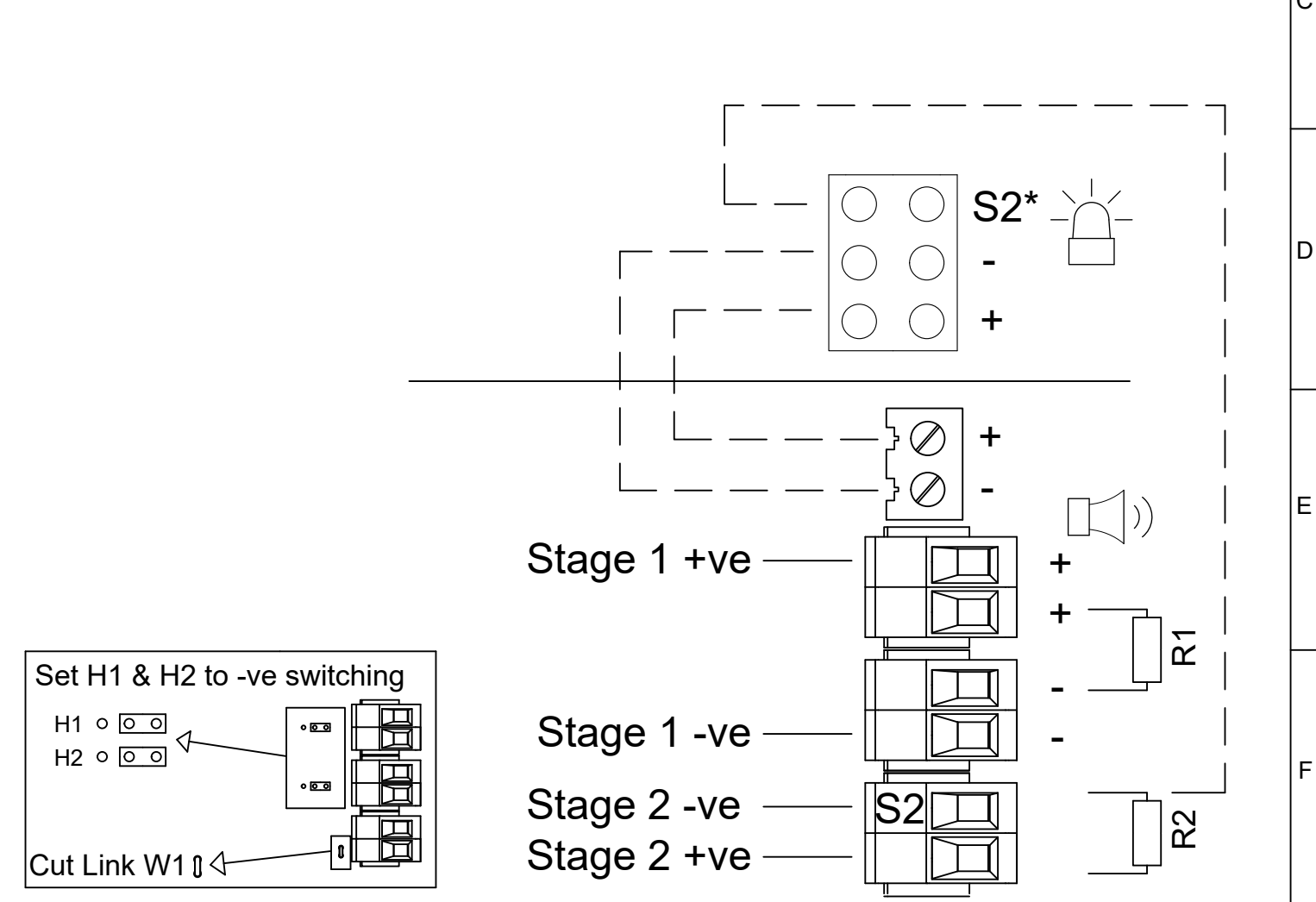
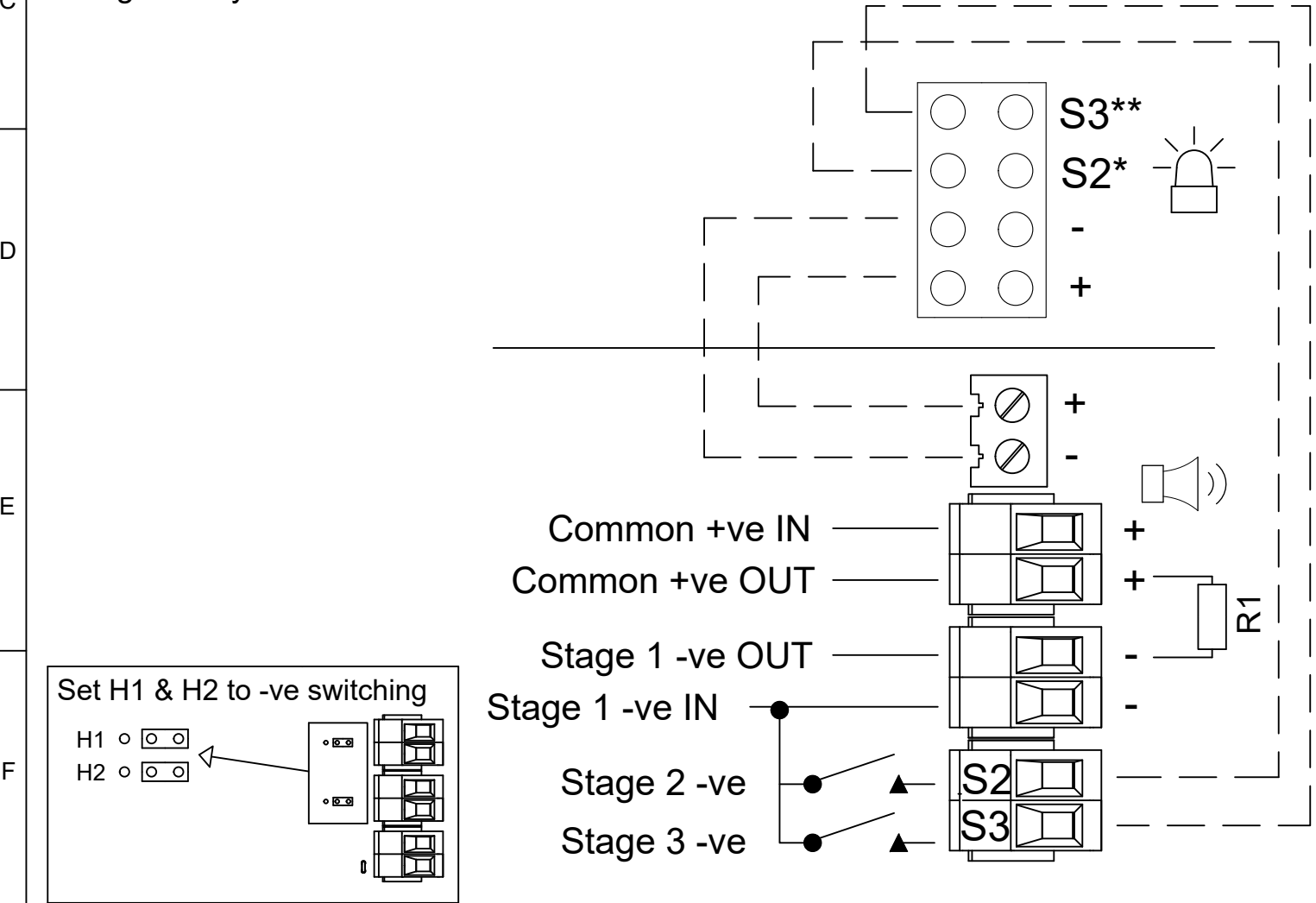

DRAWING TO BS8888:2000 GEOMETRIC TOLERANCES TO ISO1101:1983 LINEAR DIMENSIONAL TOLS ANGULAR DIMENSIONAL TOLS	DRAWN	DATE
	J.SPILLER	28/06/2021
	CHECKED	DATE
STANDARDS	B.ISARD	28/06/2021
	APPROVED	DATE
SPECTRALARM RANGE	R.N.POTTS	28/06/2021

SURFACE FINISH	WEIGHT (Kg)
MATERIAL	
ALTERNATIVE MATERIAL	

THIS DRAWING AND ANY INFORMATION OR DESCRIPTIVE
MATTER THEREIN IS COMMUNICATED IN CONFIDENCE AND
IS THE COPYRIGHT PROPERTY OF EUROPEAN SAFETY
SYSTEMS LTD. NEITHER THE WHOLE OR ANY EXTRACT MAY
BE DISCLOSED, LOANED, COPIED OR USED FOR
MANUFACTURING OR TENDERING PURPOSES WITHOUT THEIR
WRITTEN CONSENT.

ALL DIMENSIONS IN MM IF IN DOUBT, ASK - DO NOT SCALE			A3
TITLE AB112/AB121 COMBINED SOUNDER & BEACON WIRING DIAGRAMS			
SCALE	SHEET	DRAWING NUMBER	
NTS	2 OF 8	D118-06-501	

1	2	3	4	5	6	7	8	9	10
							ISSUE	MOD No.	REASON - INITIAL - DATE
							A		INTRODUCTION JS- 28/06/2021

— — WIRING LINKING BEACON & SOUNDER
FACTORY FITTED

OPTIONAL LINE MONITORING RESISTOR, CUSTOMER SUPPLIED,
RECOMMENDED MINIMUM VALUES:
14V MAX SYSTEM = 120Ω MIN, 2W MIN OR 1KΩ MIN, 0.5W MIN
28V MAX SYSTEM = 470Ω MIN, 2W MIN OR 2.4KΩ MIN, 0.5W MIN

SWITCHES FOR STAGE OPERATION
CUSTOMER SUPPLIED

Linked Sounder & Beacon Activation (Default)

Two Stage Configuration		Config.: 4
independent Stage Input		
Line Stage Monitoring (Use suitable monitoring relays/modules)		
Not to be used for reverse polarity monitoring		
Stage 1: Apply Power to Stage 1 +ve & Stage 1 -ve		
Stage 1: Apply Power to Stage 2 +ve & Stage 2 -ve		

*Stage 2 only available for AB112S, AB112L or AB121L beacons

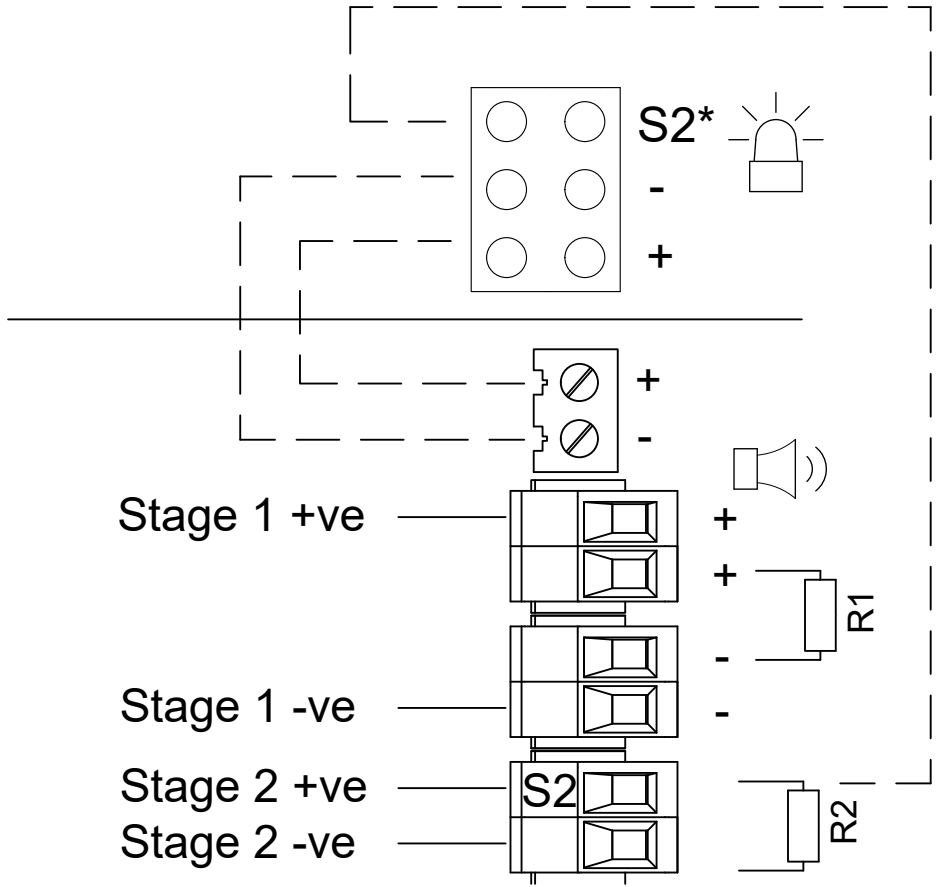

CUSTOM
CONFIGURATION
CONTACT E2S
WHEN ORDERING

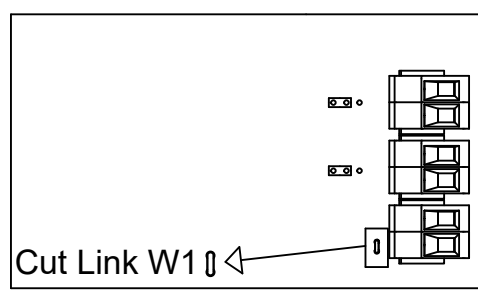

DRAWING TO BS8888:2000 GEOMETRIC TOLERANCES TO ISO1101:1983 LINEAR DIMENSIONAL TOLS ANGULAR DIMENSIONAL TOLS	DRAWN	DATE	SURFACE FINISH	WEIGHT (Kg)	THIS DRAWING AND ANY INFORMATION OR DESCRIPTIVE MATTER THEREIN IS COMMUNICATED IN CONFIDENCE AND IS THE COPYRIGHT PROPERTY OF EUROPEAN SAFETY SYSTEMS LTD. NEITHER THE WHOLE OR ANY EXTRACT MAY BE DISCLOSED, LOANED, COPIED OR USED FOR MANUFACTURING OR TENDERING PURPOSES WITHOUT THEIR WRITTEN CONSENT.	ALL DIMENSIONS IN MM		A3
	J.SPILLER	28/06/2021	MATERIAL			IF IN DOUBT, ASK - DO NOT SCALE		
	CHECKED	DATE	ALTERNATIVE MATERIAL			TITLE AB112/AB121 COMBINED SOUNDER & BEACON WIRING DIAGRAMS		
	B.ISARD	28/06/2021						
STANDARDS	APPROVED	DATE			SCALE	SHEET	DRAWING NUMBER	
SPECTRALARM RANGE	R.N.POTTS	28/06/2021			NTS	3 OF 8	D118-06-501	

OPTIONAL LINE MONITORING RESISTOR, CUSTOMER SUPPLIED,
RECOMMENDED MINIMUM VALUES:
14V MAX SYSTEM = 120Ω MIN, 2W MIN OR 1KΩ MIN, 0.5W MIN
28V MAX SYSTEM = 470Ω MIN, 2W MIN OR 2.4KΩ MIN, 0.5W MIN

Independent Sounder & Beacon Activation (Remove Link Wires)

Single Stage Configuration	Config.: 5a	Two Stage Configuration	Config.: 5b	Three/Four Stage Configuration	Config.: 5c
Line Monitoring Set to positive switching (default)		Common Negative Set to positive switching (default)		Common Negative Set to positive switching (default)	
Stage 1: Apply Power to Stage 1 +ve & Stage 1 -ve		Stage 1: Apply Power to Stage 1 +ve & Common -ve Stage 2: Apply Power to Stage 2 +ve & Common -ve		Stage 1: Apply Power to Stage 1 +ve & Common -ve Stage 2: Apply Power to Stage 2 +ve & Common -ve Stage 3: Apply Power to Stage 3 +ve & Common -ve Stage 4: Apply Power to Stage 2 +ve, Stage 3 +ve & Common -ve	

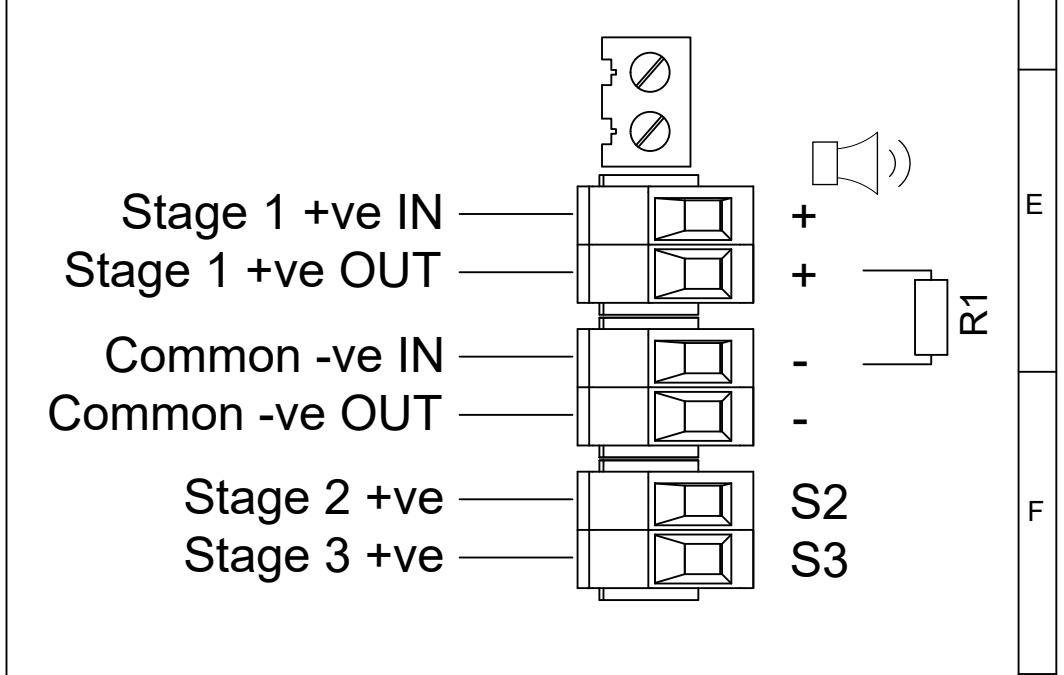
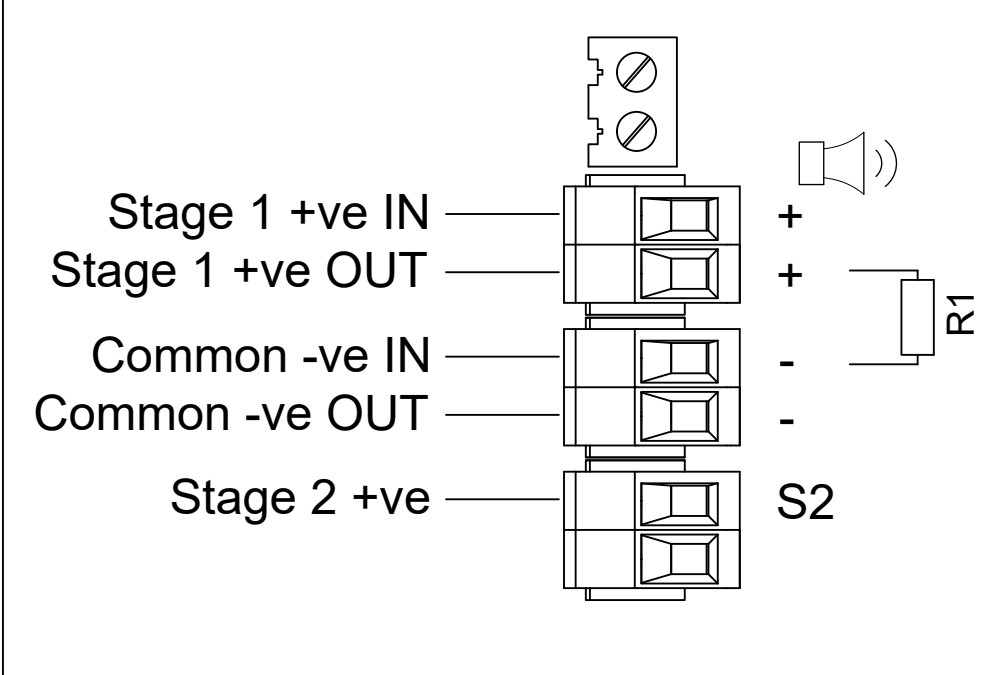
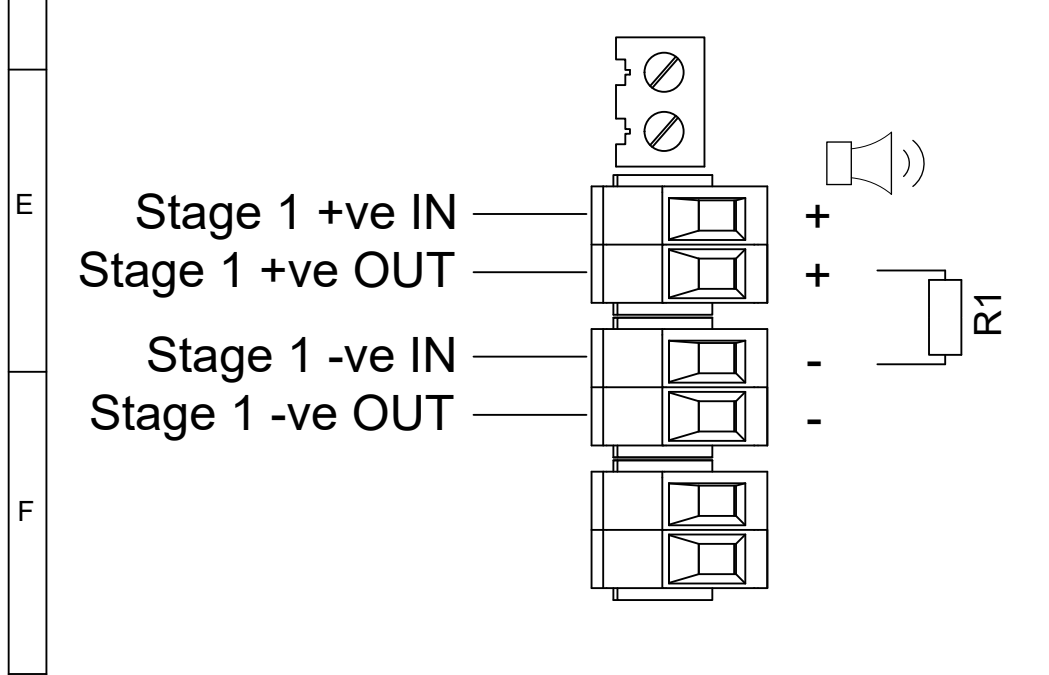
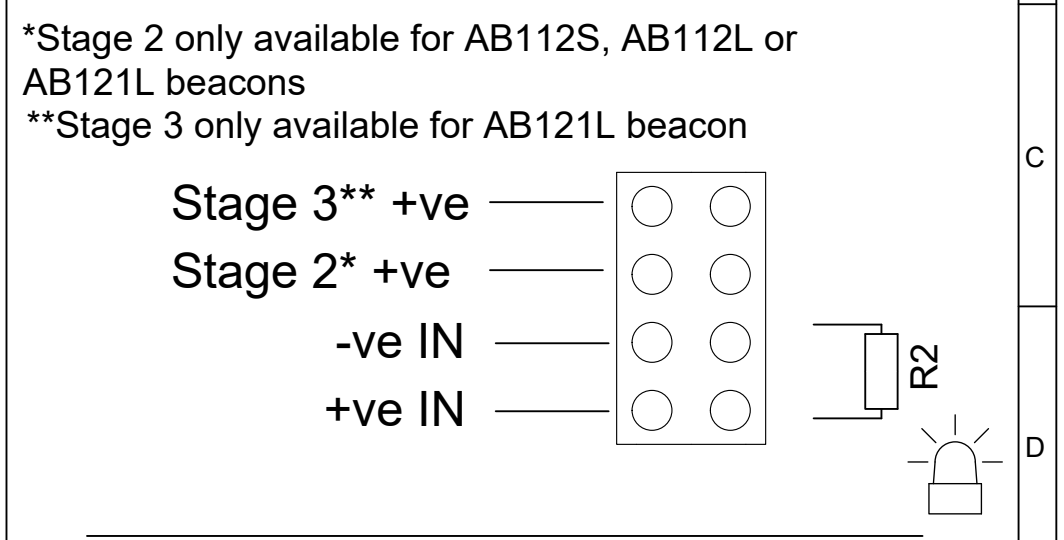
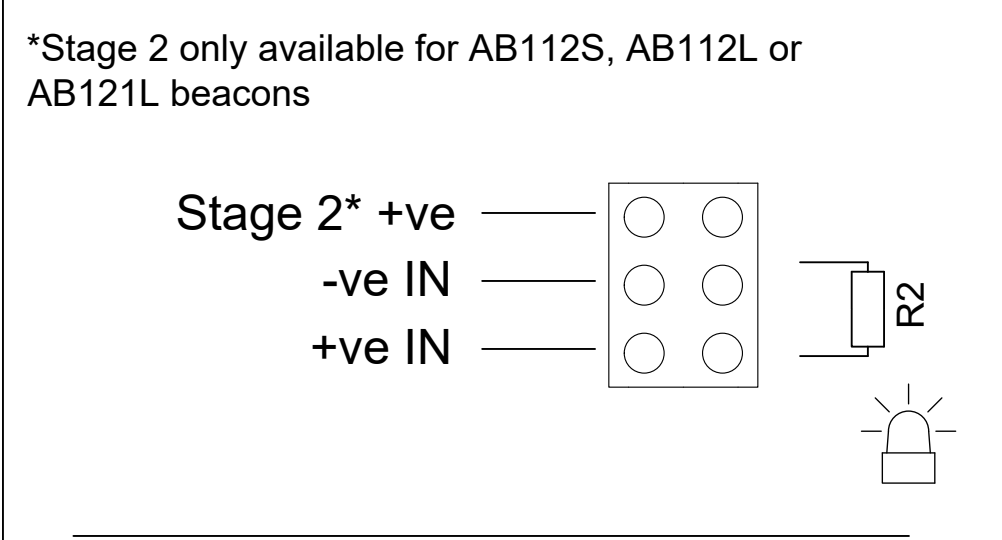
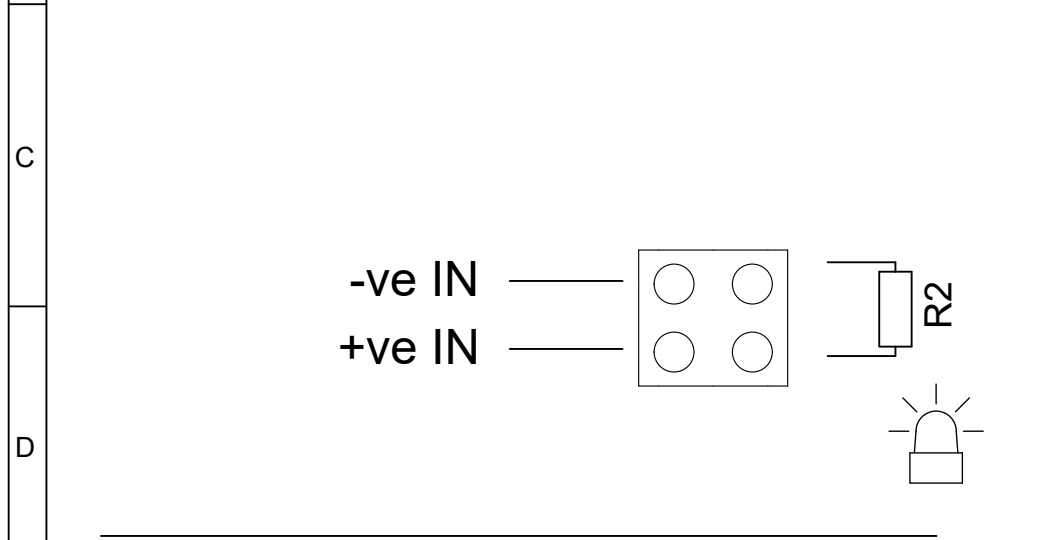

OPTIONAL LINE MONITORING RESISTOR, CUSTOMER SUPPLIED,
RECOMMENDED MINIMUM VALUES:
14V MAX SYSTEM = 120Ω MIN, 2W MIN OR 1KΩ MIN, 0.5W MIN
28V MAX SYSTEM = 470Ω MIN, 2W MIN OR 2.4KΩ MIN, 0.5W MIN

SWITCHES FOR STAGE OPERATION
CUSTOMER SUPPLIED

Independent Sounder & Beacon Activation (Remove Link Wire)

Three/Four Stages. Voltage Free 2nd, 3rd & 4th Stage Activation Configuration	Config.: 6	Two Stage Configuration	Config.: 7
---	------------	-------------------------	------------

Common Positive
Customer Set H1 & H2 to Negative Switching (See Below)

Stage 1: Apply Power to Common +ve & Stage 1 -ve
 Stage 2: Apply Power to Common +ve & Stage 1 -ve & connect Stage 2 -ve to Stage 1 -ve
 Stage 3: Apply Power to Common +ve & Stage 1 -ve & connect Stage 3 -ve to Stage 1 -ve
 Stage 4: Apply Power to Common +ve & Stage 1 -ve
 & connect Stage 2 -ve & Stage 3 -ve to Stage 1 -ve

Independent Stage Input
Reverse Polarity Stage Monitoring

Stage 1: Apply Power to Stage 1 +ve & Stage 1 -ve
 Stage 2: Apply Power to Stage 1 +ve & Stage 1 -ve & connect Stage 2 -ve to Stage 1 -ve

*Stage 2 only available for AB112S, AB112L or AB121L beacons
 **Stage 3 only available for AB121L beacon

*Stage 2 only available for AB112S, AB112L or AB121L beacons

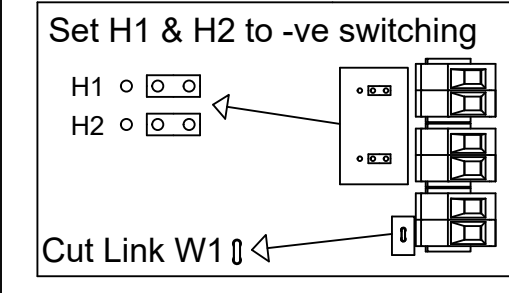
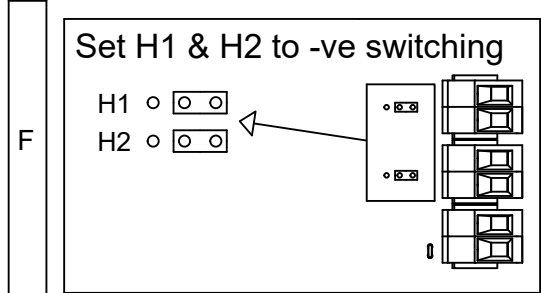
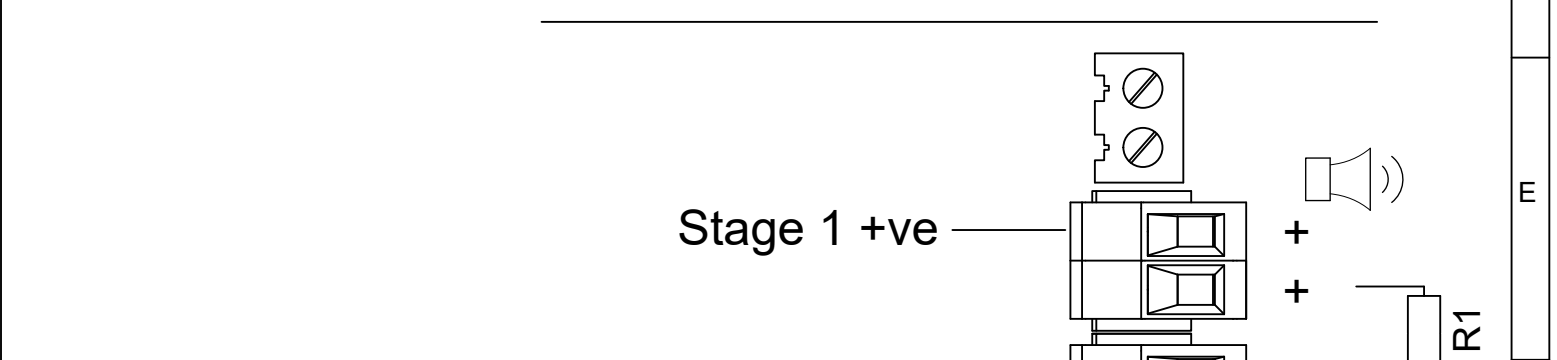
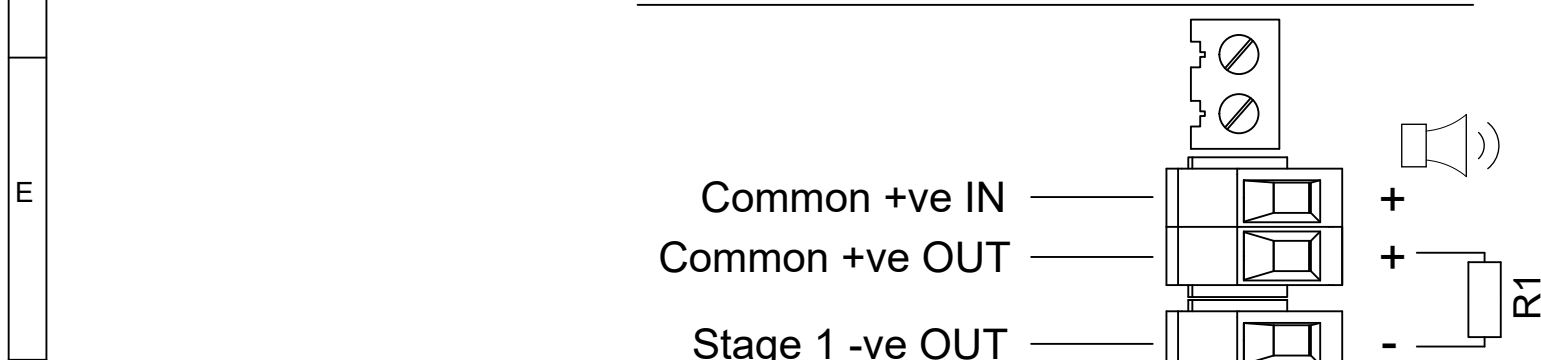
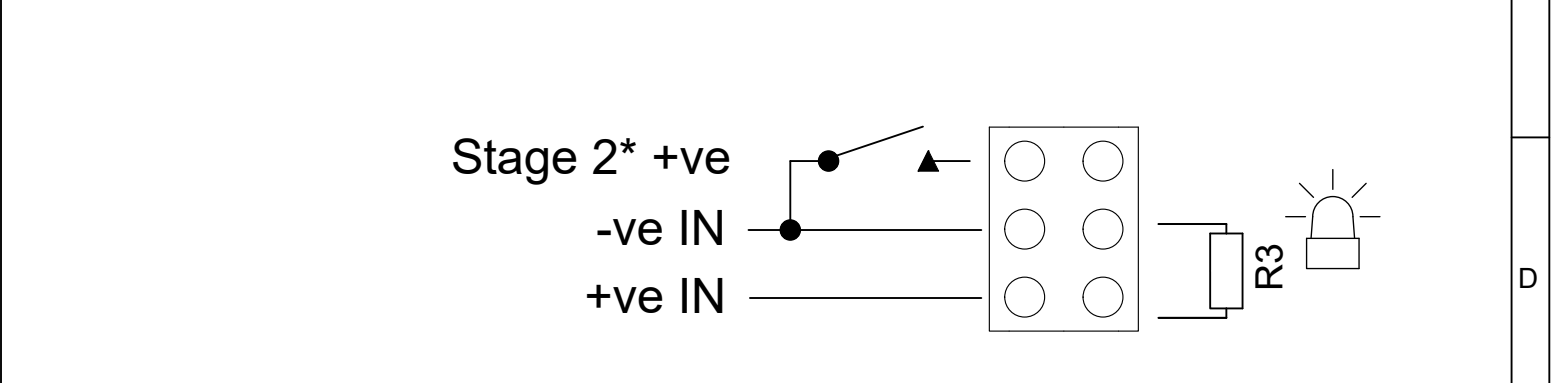
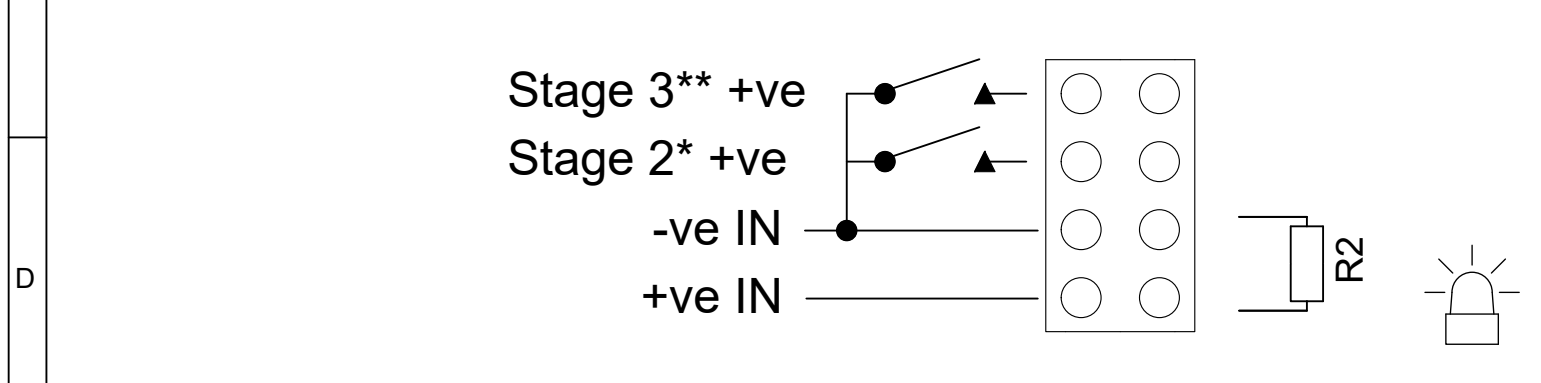

DRAWING TO BS8888:2000 GEOMETRIC TOLERANCES TO ISO1101:1983 LINEAR DIMENSIONAL TOLS ANGULAR DIMENSIONAL TOLS	DRAWN	DATE	SURFACE FINISH	WEIGHT (Kg)	THIS DRAWING AND ANY INFORMATION OR DESCRIPTIVE MATTER THEREIN IS COMMUNICATED IN CONFIDENCE AND IS THE COPYRIGHT PROPERTY OF EUROPEAN SAFETY SYSTEMS LTD. NEITHER THE WHOLE OR ANY EXTRACT MAY BE DISCLOSED, LOANED, COPIED OR USED FOR MANUFACTURING OR TENDERING PURPOSES WITHOUT THEIR WRITTEN CONSENT.	ALL DIMENSIONS IN MM IF IN DOUBT, ASK - DO NOT SCALE		A3	
	J.SPILLER	28/06/2021					TITLE AB112/AB121 COMBINED SOUNDER & BEACON WIRING DIAGRAMS		
	CHECKED	DATE					SCALE	SHEET	DRAWING NUMBER
	B.ISARD	28/06/2021					NTS	5 OF 8	D118-06-501
STANDARDS	APPROVED	DATE	ALTERNATIVE MATERIAL						
SPECTRALARM RANGE	R.N.POTTS	28/06/2021							

1	2	3	4	5	6	7	8	9	10
							ISSUE	MOD No.	REASON - INITIAL - DATE
							A		INTRODUCTION JS- 28/06/2021

OPTIONAL LINE MONITORING RESISTOR, CUSTOMER SUPPLIED,
RECOMMENDED MINIMUM VALUES:
14V MAX SYSTEM = 120Ω MIN, 2W MIN OR 1KΩ MIN, 0.5W MIN
28V MAX SYSTEM = 470Ω MIN, 2W MIN OR 2.4KΩ MIN, 0.5W MIN



SWITCHES FOR STAGE OPERATION
CUSTOMER SUPPLIED



Independent Sounder & Beacon Activation (Remove Link Wires)

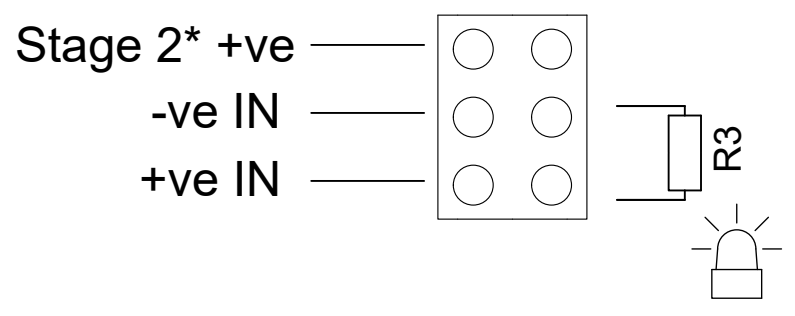

Two Stage Configuration				Config.: 8
Independent Stage Input				
Line Stage Monitoring (Use suitable monitoring relays/modules)				
Not to be used for reverse polarity monitoring				
Stage 1: Apply Power to Stage 1 +ve & Stage 1 -ve				
Stage 1: Apply Power to Stage 2 +ve & Stage 2 -ve				

*Stage 2 only available for AB112S, AB112L or AB121L beacons				
--	--	--	--	--

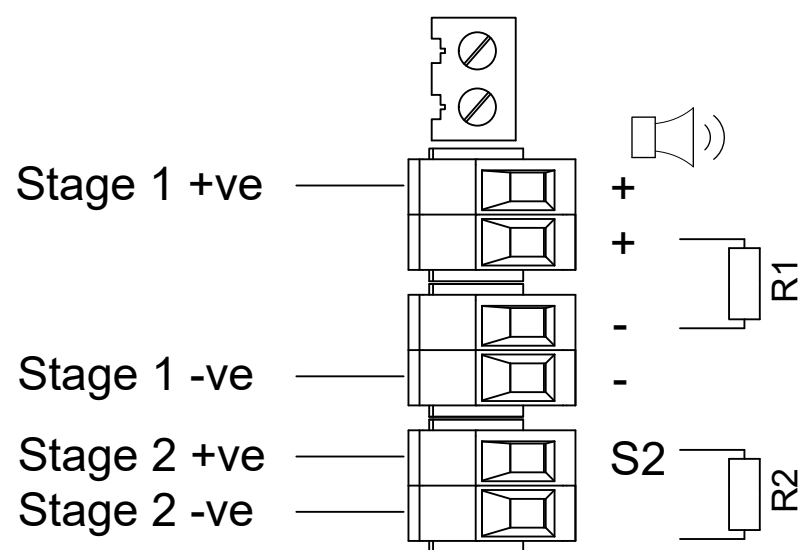
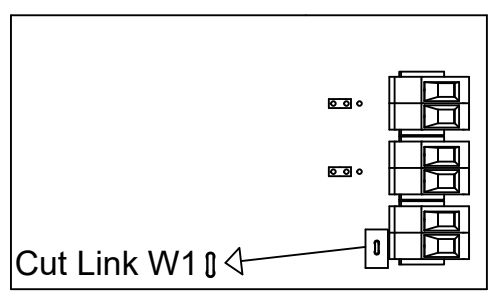

CUSTOM CONFIGURATION CONTACT E2S WHEN ORDERING



G	DRAWING TO BS8888:2000 GEOMETRIC TOLERANCES TO ISO1101:1983 LINEAR DIMENSIONAL TOLS ANGULAR DIMENSIONAL TOLS	DRAWN J.SPILLER	DATE 28/06/2021	SURFACE FINISH	WEIGHT (Kg)	THIS DRAWING AND ANY INFORMATION OR DESCRIPTIVE MATTER THEREIN IS COMMUNICATED IN CONFIDENCE AND IS THE COPYRIGHT PROPERTY OF EUROPEAN SAFETY SYSTEMS LTD. NEITHER THE WHOLE OR ANY EXTRACT MAY BE DISCLOSED, LOANED, COPIED OR USED FOR MANUFACTURING OR TENDERING PURPOSES WITHOUT THEIR WRITTEN CONSENT.	ALL DIMENSIONS IN MM IF IN DOUBT, ASK - DO NOT SCALE			A3
	STANDARDS SPECTRALARM RANGE	CHECKED B.ISARD	DATE 28/06/2021	MATERIAL	ALTERNATIVE MATERIAL		TITLE AB112/AB121 COMBINED SOUNDER & BEACON WIRING DIAGRAMS			
		APPROVED R.N.POTTS	DATE 28/06/2021				SCALE NTS	SHEET 6 OF 8	DRAWING NUMBER D118-06-501	

----- WIRING LINKING BEACON & SOUNDER
FACTORY FITTED

SWITCHES FOR STAGE OPERATION
CUSTOMER SUPPLIED

Linked Sounder & Beacon Activation (Default)

Single Stage Configuration Config.: 9a

Three/Four Stage Configuration Config.: 9b

Stage 1: Apply Power to Stage 1 Live & Stage 1 Neutral

Stage 1: Apply Power to Live & Neutral
Stage 2: Apply Power to Live & Neutral & connect Stage 2 to Common
Stage 3: Apply Power to Live & Neutral & connect Stage 3 to Common

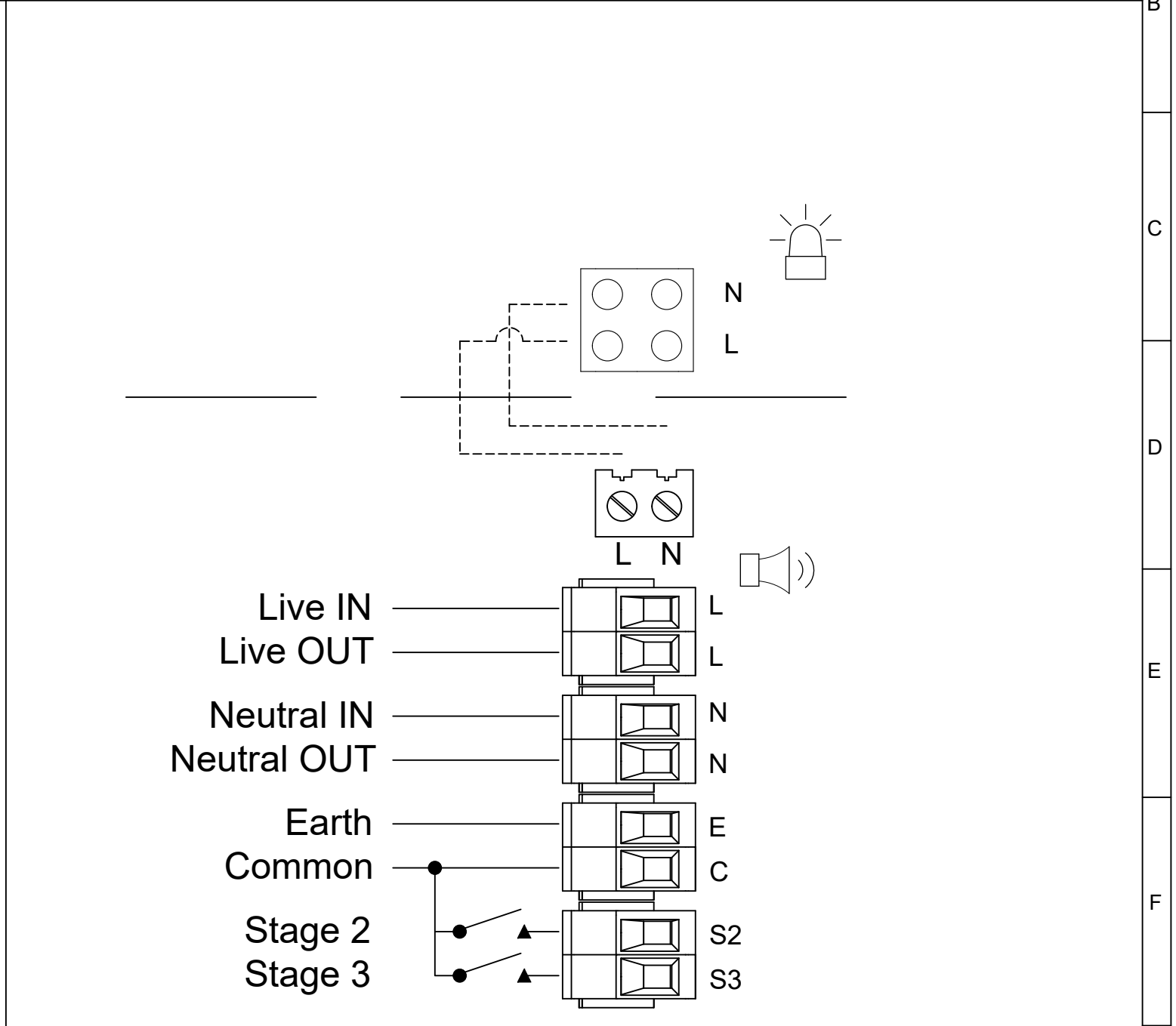
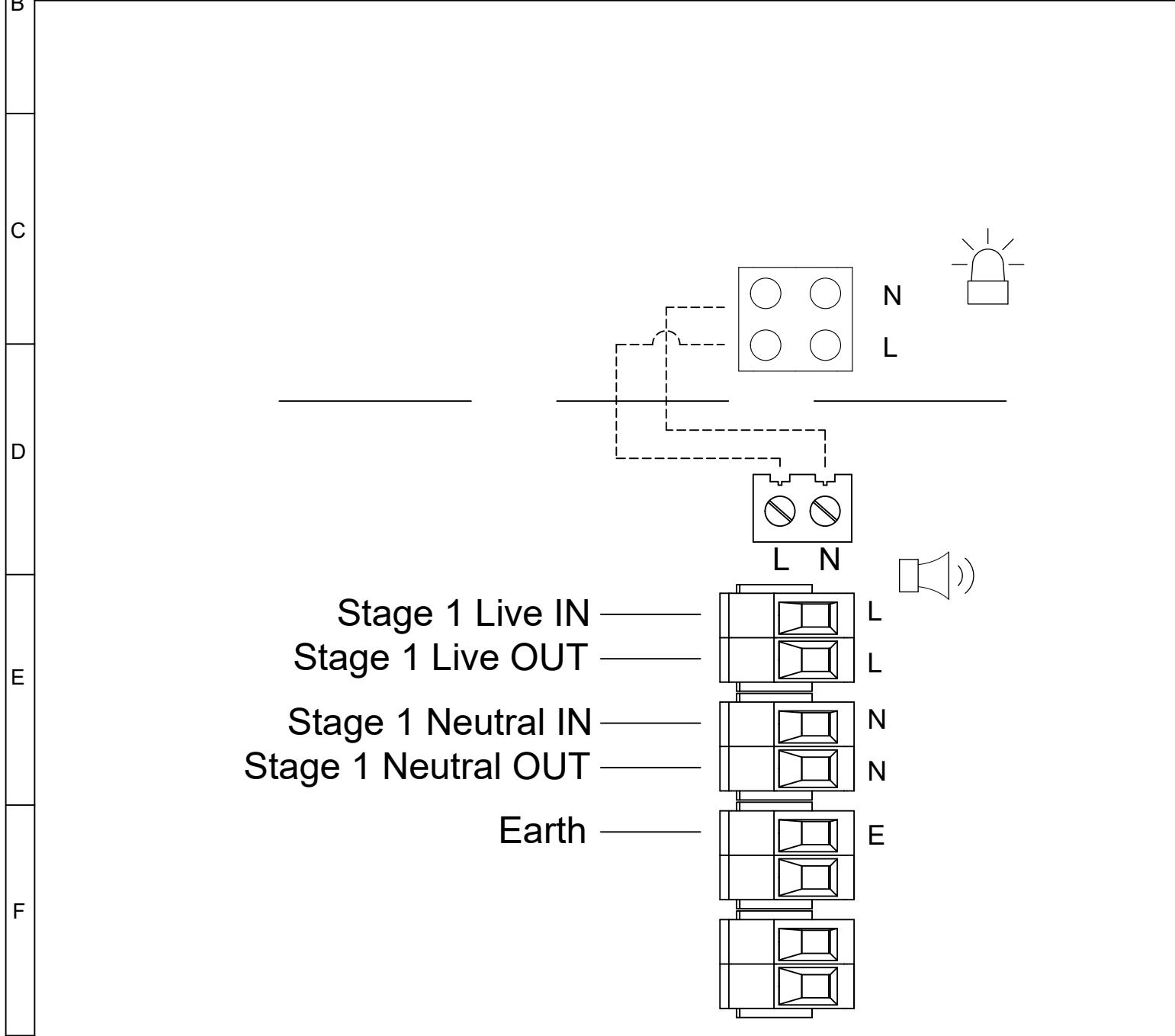

DRAWING TO BS8888:2000
GEOMETRIC TOLERANCES TO ISO1101:1983
LINEAR DIMENSIONAL TOLS
ANGULAR DIMENSIONAL TOLS

STANDARDS
SPECTRALARM RANGE

DRAWN	DATE
J.SPILLER	28/06/2021
CHECKED	DATE
B.ISARD	28/06/2021
APPROVED	DATE
R.N.POTTS	28/06/2021

SURFACE FINISH	WEIGHT (Kg)
MATERIAL	
ALTERNATIVE MATERIAL	

THIS DRAWING AND ANY INFORMATION OR DESCRIPTIVE
MATTER THEREIN IS COMMUNICATED IN CONFIDENCE AND
IS THE COPYRIGHT PROPERTY OF EUROPEAN SAFETY
SYSTEMS LTD. NEITHER THE WHOLE OR ANY EXTRACT MAY
BE DISCLOSED, LOANED, COPIED OR USED FOR
MANUFACTURING OR TENDERING PURPOSES WITHOUT THEIR
WRITTEN CONSENT.

ALL DIMENSIONS IN MM
IF IN DOUBT, ASK -
DO NOT SCALE

A3
TITLE AB112/AB121 COMBINED SOUNDER & BEACON WIRING DIAGRAMS
SCALE: NTS SHEET: 7 OF 8 DRAWING NUMBER: D118-06-501

SWITCHES FOR STAGE OPERATION
CUSTOMER SUPPLIED

Independent Sounder & Beacon Activation (Remove Link Wires)

Single Stage Configuration Config.: 10a
 Stage 1: Apply Power to Stage 1 Live & Stage 1 Neutral

Three/Four Stage Configuration Config.: 10b
 Stage 1: Apply Power to Live & Neutral
 Stage 2: Apply Power to Live & Neutral & connect Stage 2 to Common
 Stage 3: Apply Power to Live & Neutral & connect Stage 3 to Common

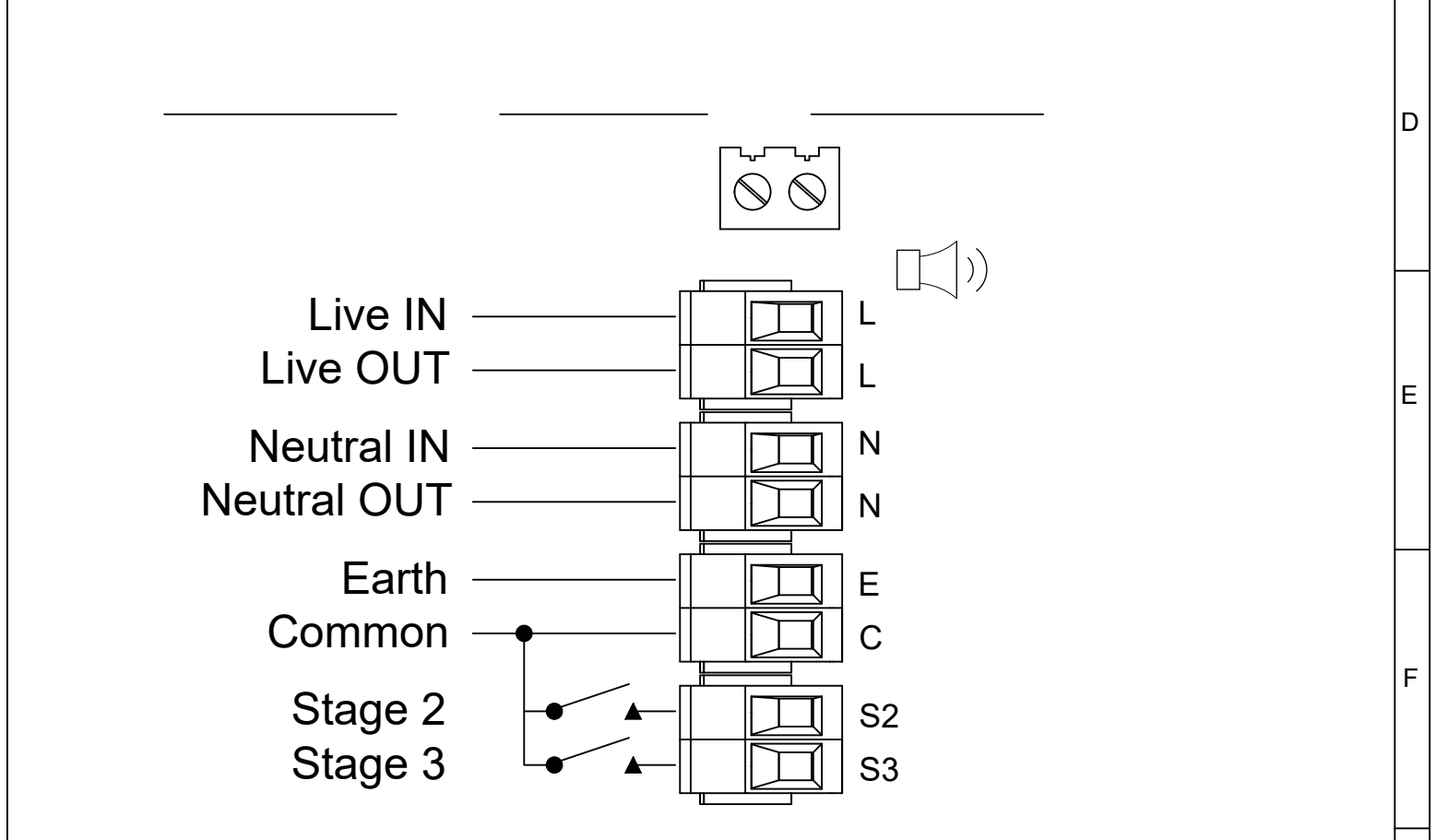
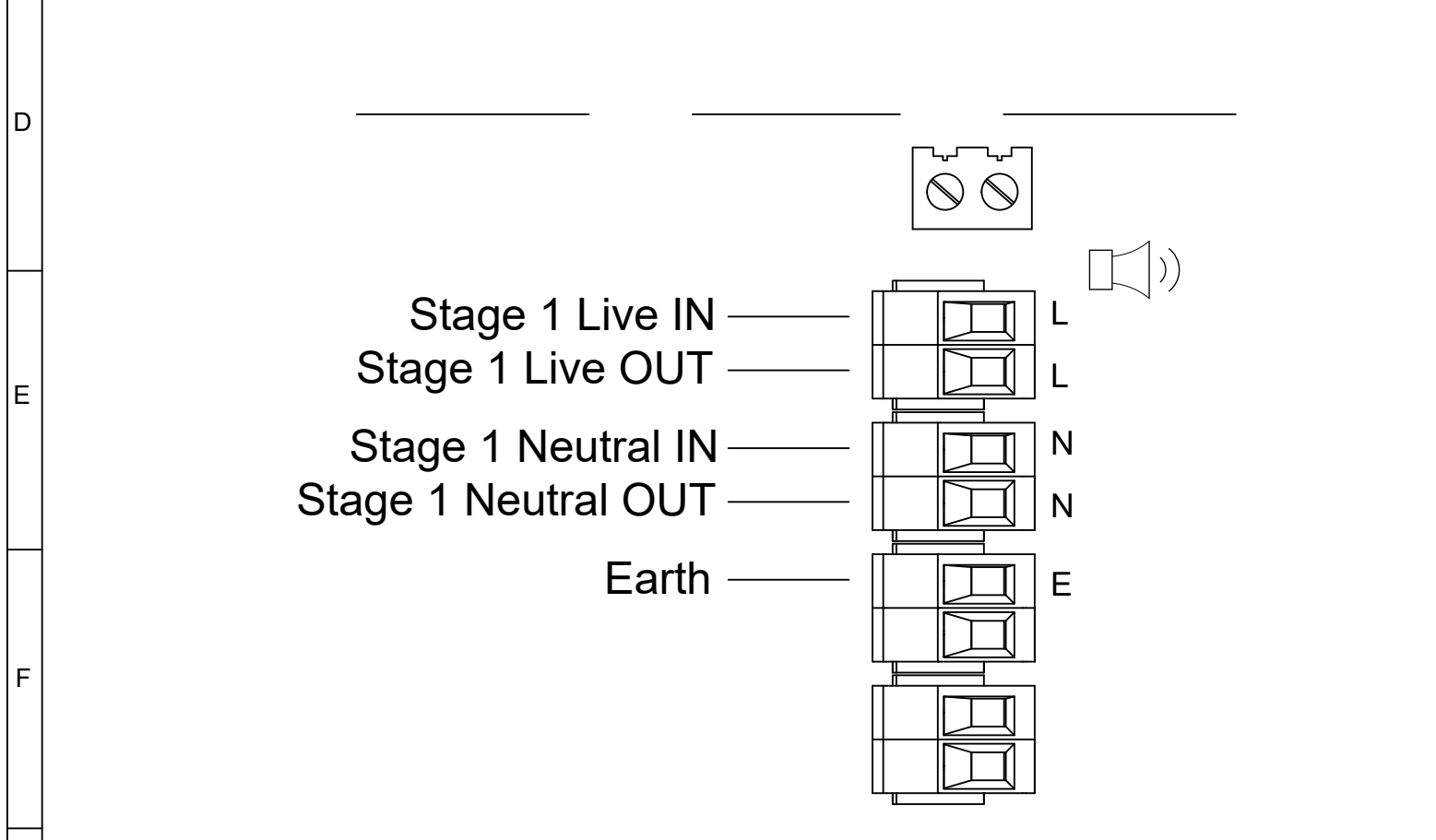
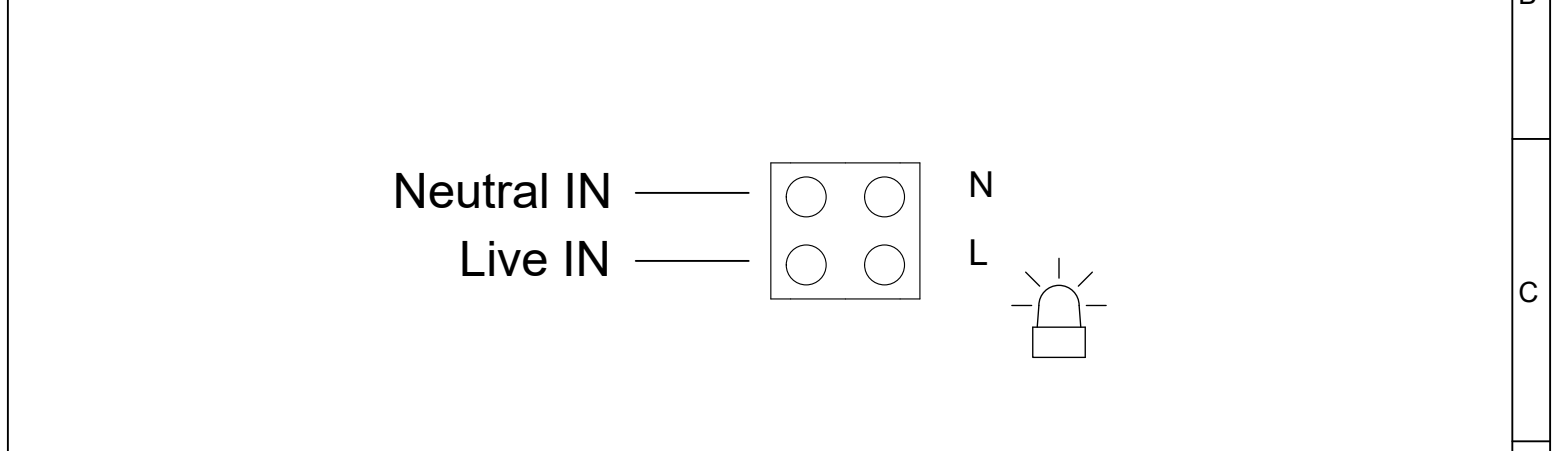
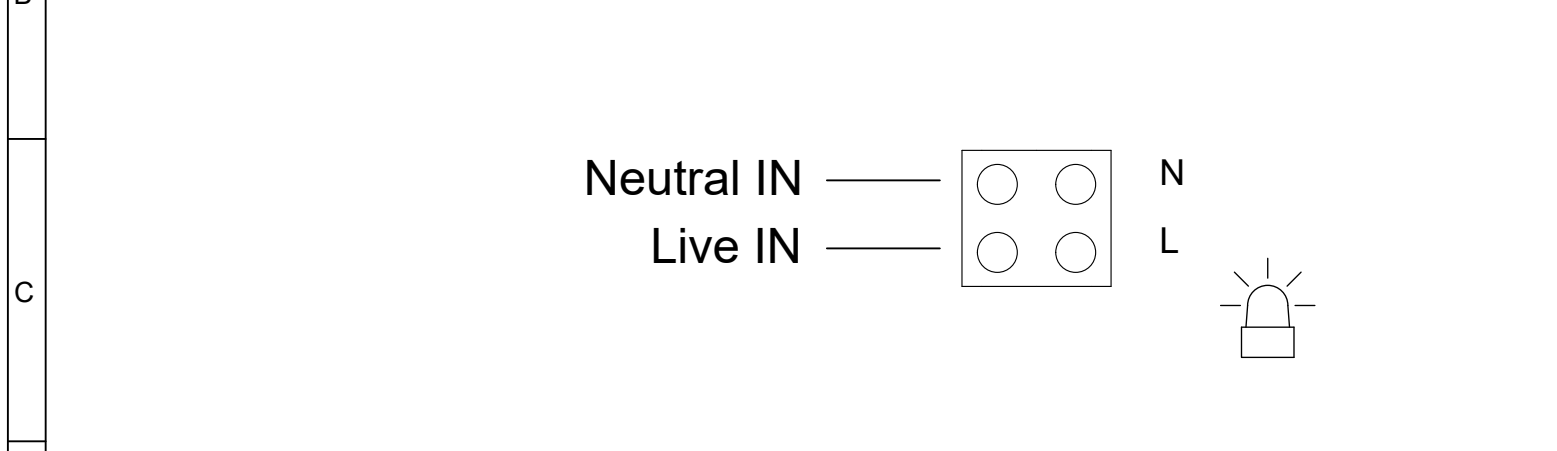

DRAWING TO BS8888:2000 GEOMETRIC TOLERANCES TO ISO1101:1983 LINEAR DIMENSIONAL TOLS ANGULAR DIMENSIONAL TOLS	DRAWN	DATE	SURFACE FINISH	WEIGHT (Kg)	THIS DRAWING AND ANY INFORMATION OR DESCRIPTIVE MATTER THEREIN IS COMMUNICATED IN CONFIDENCE AND IS THE COPYRIGHT PROPERTY OF EUROPEAN SAFETY SYSTEMS LTD. NEITHER THE WHOLE OR ANY EXTRACT MAY BE DISCLOSED, LOANED, COPIED OR USED FOR MANUFACTURING OR TENDERING PURPOSES WITHOUT THEIR WRITTEN CONSENT.	ALL DIMENSIONS IN MM IF IN DOUBT, ASK - DO NOT SCALE		A3
	J.SPILLER	28/06/2021				TITLE AB112/AB121 COMBINED SOUNDER & BEACON WIRING DIAGRAMS		
	CHECKED	DATE	ALTERNATIVE MATERIAL			SCALE	SHEET	DRAWING NUMBER
	B.ISARD	28/06/2021				NTS	8 OF 8	D118-06-501
STANDARDS	APPROVED	DATE						
SPECTRALARM RANGE	R.N.POTTS	28/06/2021						