



## BEACONS

Lightbars | Minibars | Directional LEDs | Worklamps | Back-Up Alarms | Camera Systems

## 6465 Series

SAE Class III LED

ECCO's maintenance free 6465 Series LED Beacon features a Pulse8 flash pattern, producing a warning signal that is ideal for industrial-type applications. The long, maintenance-free service life of LED technology, make this a perfect replacement solution for existing strobe beacons. This cost-effective light features a wide 12-80V operating range that also makes it ideal for use on electrically-powered vehicles and equipment.

### Models

PART NO.	VOLTAGE	AMPS	FPM	MOUNT
6465X	12-80	0.45	75 Pulse8	3 Bolt
6465X-MG	12-80	0.45	75 Pulse8	Magnet

Replace X in part number with desired color: A=amber, B=blue, C=clear, G=green, R=red

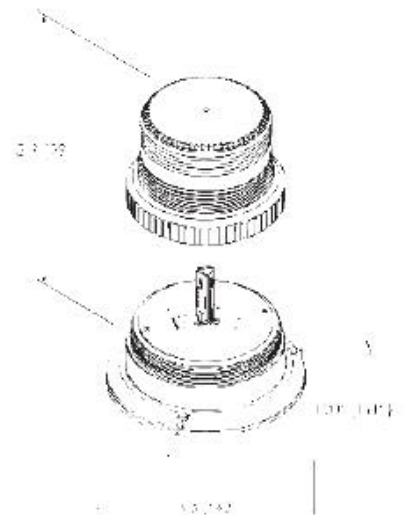

### Features and Benefits

- 12-80V
- Pulse8 (8 flash per cycle) flash pattern
- Reinforced-nylon base and polycarbonate lens
- SAE Class 3, CE, e, UL
- Temperature Range: -30°C to +50°C

### Parts & Accessories

- Lenses:
  - Amber - R6400LA
  - Blue - R6400LB
  - Clear - R6400LC
  - Green - R6400LG
  - Red - R6400LR