

Explosionproof version of the  
weatherproof FernTel 3 telephone

# *FernTel 3 Z2*



Instructions



The FernTel 3 Z2 telephone is an explosionproof version of the weatherproof FernTel 3 telephone with all its features. The operating manual is still valid, with the addition of the following items.

## **Operation**

The FernTel 3 Z2 telephone is used as a stationary device in areas potentially endangered by an explosive gas or dust atmosphere.

Designed for Device Group II and Categories 3G and 3D, it may be operated within zones 2 and 22.

The FernTel 3 Z2 telephone may only be operated in the analogue, public telephone network and via analogue terminals of branch exchanges.

## **Commissioning**

After having been connected to the telephone line, the telephone is operational.

## **Operating utilization position**

The telephone may be mounted on a wall or used as a desk telephone.

## **Service**

The telephone contains no serviceable parts.

## **Care and maintenance**

The telephone is maintenance-free. Still, if the operating area is highly contaminated by dust, fat, oil etc., the device should be cleaned from time to time.

The device may only be cleaned using a damp cloth in order to avoid electrostatic charging.

Never use sharp objects for cleaning.

During maintenance, check accessible seals for function, e.g. regarding possible damage or positioning. If the seals are damaged, operating the telephone is not allowed. Damaged seals must be replaced.

## **Disposal**

The complete device should be disposed of as electronic waste. When the device is disassembled, plastics, metals and electronics components are to be disposed of separately. In every single case the national requirements and regulations for waste disposal must be observed.

## Warnings and security information

This device is an explosionproof, weatherproof telephone especially designed for use in rough industrial environments.

### **Please note the following warnings and security information:**

- The installation and adjustment of the device must be carried out by qualified personnel in accordance with the prescribed installation regulations taking the specified types of protection into account.
- This apparatus is a Protective Class II device and may only be connected to and operated at the voltage it was designed for.

Make sure the connections are in perfect order.

- Make sure the telephone housing, the connecting cable and the receiver cord are not damaged. If the device is damaged, it may not be operated.
- While operating the device in commercial facilities, the accident prevention regulations of the Employers' Liability Insurance Association regarding the use of electrical systems and devices must be observed.
- The device may be operated solely under the stated ambient conditions. Unfavourable ambient conditions can lead to damage of the device and thus present a potential danger for the user.

### **Unfavourable ambient conditions include:**

- Humidity of air too high (>75% rel., condensing)
- moisture, dust (pay attention to the degree of protection)
- flammable gases, vapours and solvents not covered by the device's type of protection
- too high ambient temperatures (>+55°C)
- too low ambient temperatures low (<-20°C)
- During operation of the device the temperature must not exceed nor fall below the prescribed range of ambient temperatures. It is not allowed to operate the device with an additional cover.
- Repairs may be carried out by the manufacturer or by a person appointed by the manufacturer followed by a renewed product conformity inspection.
- Make sure the wiring is disconnected from the power supply upon connecting or disconnecting the wires in the terminal room.
- If electrical connections must be carried through in the hazardous area, the enclosure must be opened and closed as follows:
  - Remove voltage from the device
  - Loosen the fastening screws from the keypad insert
  - Remove the keypad insert and unfasten the keypad cable

- Make the connections while the device is open
- When the work is done, plug the keypad back on, and place the keypad insert back on the lower part of the device.

Make sure the seal is correctly positioned and in perfect working order. Then tighten the fastening screws in a diagonal pattern.

- Only blind plugs and cable glands as prescribed by the manufacturer may be used.

Should these points not be observed, the explosion protection of the device cannot be guaranteed. The device then poses a potential threat to the user's life and can cause the ignition of an explosive atmosphere.

## CE symbol

The FernTel 3 Z2 fulfils the demands of the R&TTE Directive 1995/5/EC and the ATEX directive 94/9/EC. The CE symbol confirms the conformity of the device with the above-mentioned Directives.

## EMC-Directive

The device complies with the requirements of the new EMC-directive 2004/108/EC, the low voltage directive 2006/95/EC and the R&TTE directive 1999/5/EC.

The conformity with the above directives is confirmed by the CE sign.

## Technical Specifications

### Electrical characteristics

Connection data	DC voltage	La / Lb: $U_m = 66 \text{ Vdc}$
	Ringing voltage	24 Vac - 90 Vac / 16 Hz...68 Hz

Sounder input impedance	$\geq 6.0 \text{ k}\Omega$ at 25 Hz
	$\geq 3.5 \text{ k}\Omega$ at 50 Hz

### General specifications

Enquiry key (flash)	for dual-tone multifrequency only	80 ms, 120 ms, 600 ms
Dialling procedure	Dual-tone multifrequency	Frequencies according to ITU-T Q.23 Tone duration unlimited or 90 ms
	Pulse dialling	Pulse/Pause ratio 1.5 : 1 (60 ms/40 ms) or 2:1 (66.7/33.3 ms)

Ringing volume	max. approx. 95 dB(A) at 1 m distance
----------------	---------------------------------------

Housing	Height x Width x Depth	293 x 191 x 128 mm
Weight		Approx. 2300 g
Receiver	Microphone	Electret-foil microphone
	Receiver inset	dynamic receiver inset with magnetic field generator

## Connecting terminals

### Labelling

Power cable	2-pin	TCP/La - TCP/Lb
Secondary sounder cable	2-pin	W - W1

### Conductor cross section

flexible	fine-wired	0.75 – 2.5 mm <sup>2</sup> / AWG14
rigid	single wired	0.75 – 2.5 mm <sup>2</sup> / AWG14

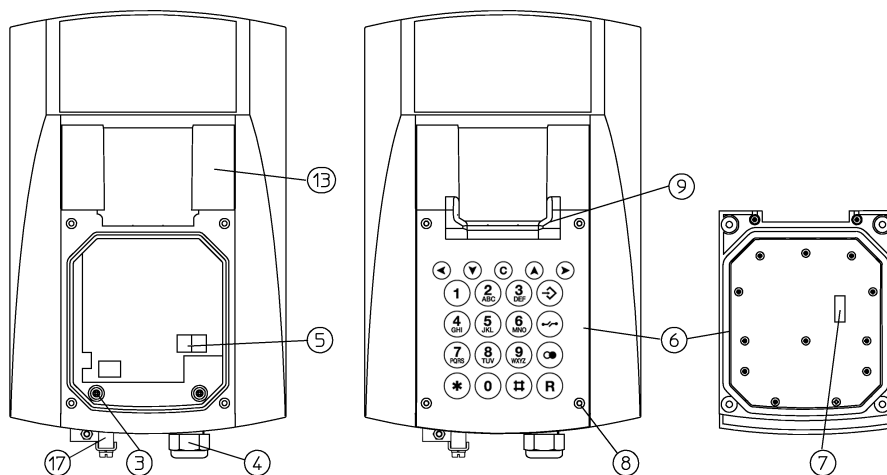

## When connecting the wire, observe the fulfilment of the Class II requirements as follows:

1. For connection always use the required terminal **(5)**
2. The shielding isolation must be long enough to reach at least to the upper edge of the cable gland.
3. The exposed conductors, from which the isolation has been removed, must be situated in the terminals.

In order to avoid electrostatic discharge, the potential must be evened out. **(17)**

## Dimensions connecting cable / cable entry

Cable entries	M20 x 1.5 / M12 x 1.5
Blind plugs	M20 x 1.5 / M12 x 1.5
Connecting cable diameter	6 – 13 mm
Connection potential compensation	1.5 – 4 mm <sup>2</sup>

## Ambient temperature range and explosion protection

Type of protection	II 3 G Ex nA ic IIC T5 Gc II 3 D Ex tc ic IIIC T80°C Dc
Ambient operating temperature	-20°C ≤ Ta ≤ +55°C
Storage and transport temperature	-25°C ≤ T ≤ +70°C
Housing degree of protection	IP 65

## Labelling

 www.fhf.de	Funke + Huster Fernsig 45478 Mülheim Made in Germany	<b>FernTel 3 Z2</b>	
Part No: 11240020	II 3 G Ex nA ic IIC T5 Gc	Ex nA ic IIC T5 Gc	
Serial No: -----	II 3 D Ex tc ic IIIC T80°C Dc	Ex tc ic IIIC T80°C Dc	
Apvd.: -----	-20°C ≤ Ta ≤ 55°C	CE <sup>0158</sup> -20°C ≤ Ta ≤ 55°C	
U <sub>m</sub> =66Vdc/90Vac	BVS 07 ATEX E 098	IECEX BVS 08.0008	
IK08 IP65	<b>ACHTUNG! Nicht unter Spannung öffnen!</b> <b>WARNING! Do not open while energized!</b> <b>ATTENTION! Ne pas ouvrir sous tension!</b>		

# EG-KONFORMITÄTSERKLÄRUNG EC DECLARATION of CONFORMITY DECLARATION CE de CONFORMITE DECLARACIÓN de CONFORMIDAD CE



Hiermit erklären wir, dass das ATEX-Produkt aufgrund seiner Konzipierung und Bauart sowie in der von uns in Verkehr gebrachten Ausführung den grundlegenden Sicherheits- und Gesundheitsanforderung der genannten Richtlinie entspricht.  
**Bei einer nicht mit uns abgestimmten Änderung des Produktes, verliert diese Konformitätserklärung ihre Gültigkeit.**

We herewith declare that the ATEX product, based on its development and type as well on the specific design we have placed on the market, conforms to the Essential Health and Safety Requirements of the mentioned directive.

**This declaration shall become invalid if any modification we have not authorised is made to the product.**

Nous attestons, par le présent document, que le produit ATEX a été conçu et fabriqué, quant au modèle mis en circulation par nos services, conformément aux exigences fondamentales de sécurité et de santé en vigueur de la ou des directives citées.

**En cas de modification du produit non convenue avec nos services, la présente déclaration perd sa validité.**

Por la presente declaramos que el producto ATEX satisface por su diseño y tipo constructivo así como en la versión comercializada por nosotros los requisitos de seguridad y salud fundamentales y pertinentes de la directiva indicada.

**En caso de una modificación del producto no acordada con nosotros, la presente declaración pierde su validez.**

Beschreibung des Gerätes	Telefon
Description of the product	Telephone
Description du produit	Téléphone
Descripción del producto	Teléfono
Typ / Type / Modèle / Tipo	<b>FernTel 3 Z2</b>
Richtlinie / Directive / Directive / Directiva	Normen / Standards / Normes / Normas
94/9/EG: Geräte und Schutzsysteme zur bestimmungsgemäßen Verwendung in explosionsgefährdeten Bereichen 94/9/EC: Equipment and protective systems intended for use in potentially explosive atmospheres 94/9/CE: Appareils et systèmes de protection destinés à être utilisés en atmosphères explosibles 94/9/CE: Aparatos y sistemas de protección para uso en atmosferas socialmente explosivas	EN 60079-0:2012 EN 60079-11:2012 EN 60079-15:2010 EN 60079-31:2013
Kennzeichnung / Marking / Marquage / Calificación	<b>II 3G Ex nA ic IIC T5 Gc II 3D Ex tc ic IIC T80°C Dc</b>
EG-Baumusterprüfbescheinigung / EC-Type Examination Certificate Attestation d'examen CE de type / Certificado de examen CE	<b>BVS 07 ATEX E 098</b>
Benannte Stelle / Notified Body / Organisme notifié / Organismo Certificado Kennnummer / identification number / numéro d'identification / numero de examen	<b>DEKRA EXAM 0158</b>
Hersteller / manufacturer / fabricant / fabricante	<b>FHF Funke + Huster Fernsig GmbH</b> Gewerbeallee 15-19 45478 Mülheim an der Ruhr Deutschland / Germany / Allemagne / Alemania

Geschäftsführer / Managing Director / Direction / Gerencia:

Schwengers, Jörg

(Name, Vorname / name, prename / nom, prénom / apellido y nombre)

Mülheim an der Ruhr  
(Ort / place / ville / Lugar)

27.03.14  
.....  
(Datum / date / date / Fecha)

  
.....  
(Unterschrift / signature / signature / Firma)

Subject to alterations  
or errors



FHF Funke + Huster Fernsig GmbH

Gewerbeallee 15-19 · D-45478 Mülheim an der Ruhr  
Phone +49/208/82 68-0 · Fax +49/208/82 68-286  
<http://www.fhf.de> · e-mail: [info@fhf.de](mailto:info@fhf.de)