

# Electronic sound generator with LED-Multifunction light DL112H

**Comax**  
Signaltechnik

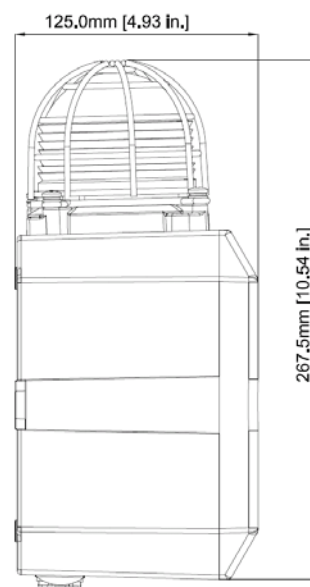

- 45 different tones
- 112dB (A) +/- 3dB
- range up to 125m
- 3 alarm stages
- 24 high intensity LED
- Aluminium case

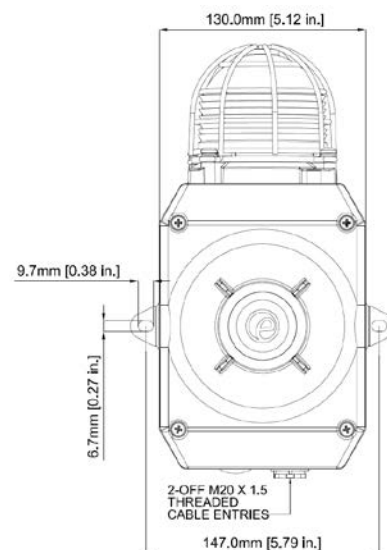

## Technical data

### LED-Multifunction light

Light source	24 Superflux high output LED
-colours	red, amber, green, blue, white
Lens	clear
Flash options	steady or flash 2Hz
Effective intensity	120cd with white LED

### Sounder

Output	max. 112dB, min. 100dB (tone 2)
Tones	45
Range	up to 125m
Alarm stages	3
-control	negative, reverse polarity on DC units
Synchronization	automatic on multi-sounder system

### Case

Material	Aluminium Al Si12 Cu
-colour	grey (RAL7038)
Fixings	stainless steel
Degree of protection	IP66 according to EN 60529
Temperature range	-25°C up to +55°C
Cable entries	2xM20-threads (1x stopping plug)
Terminals	cables up to 1.5mm <sup>2</sup>

### General

Operation	continuous
Weight	DC: 2.8kg, AC 3.1kg
Options	Tropicalized version, UL approval Case red (RAL3000)

## Order data

No. of article	Tension	Output	Current
DL112H.024.2*	12-30VDC	approx. 112dB(A),1m	Sounder 200mA / LED 157mA
DL112H.048.2*	35-60VDC	approx. 112dB(A),1m	Sounder 120mA / LED 55mA
DL112H.115.7*	115VAC	approx. 112dB(A),1m	Sounder 100mA / LED 60mA
DL112H.230.7*	230VAC	approx. 112dB(A),1m	Sounder 60mA / LED 35mA

**Colours of LED:** 1=red, 2=amber, 4=green, 5=blue, 6=white

Modification of technical details without prior notice



**Comax**  
Signaltechnik

Comax Industrielle Signaltechnik AG, Thalstrasse 279, CH-4712 Laupersdorf/Schweiz  
Tel +41 32 617 31 41 E- mail@comax.ch Internet www.comax.ch