

# Electronic sound generator with xenon strobe light DL112X

**Comax**  
Signaltechnik

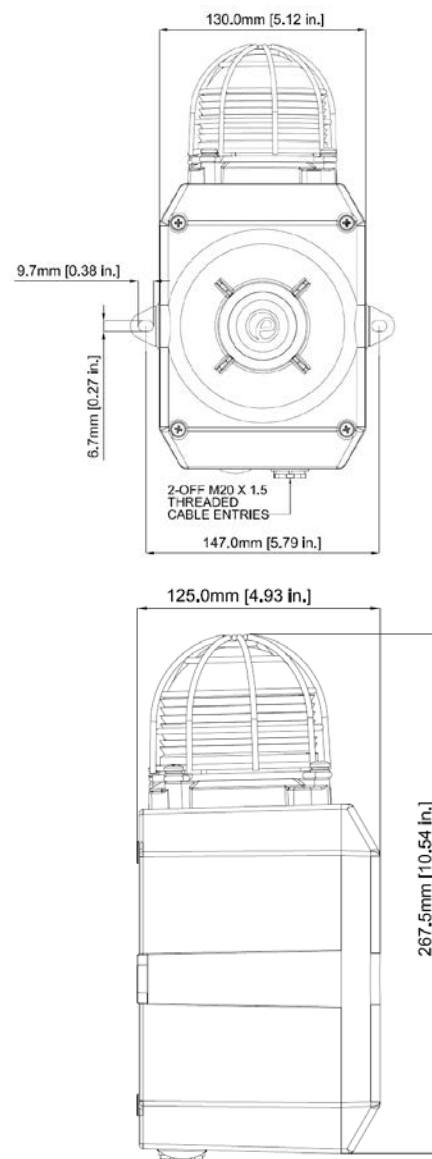

- 45 different tones
- 112dB (A) +/- 3dB
- range up to 125m
- 3 alarm stages
- 5 Joules
- Aluminium case



## Technical data

### Strobe light

Light source	Xenon tube
Colours of lens	red, amber, yellow, green, blue, clear
Flash rate	1Hz/1,5Hz/Double strike flash
Strobe	5 Joule
	200cd with clear lens

### Sounder

Output	max. 112dB, min. 100dB (tone 2)
Tones	45
Range	up to 125m
Alarm stages	3
-control	negative, reverse polarity on DC units
Synchronization	automatic on multi-sounder system

### Case

Material	Aluminium A1 Si12 Cu
-colour	grey (RAL7038)
Fixings	stainless steel
Degree of protection	IP66 according to EN 60529
Temperature range	-25°C up to +55°C
Cable entries	2xM20-threads (1x stopping plug)
Terminals	cables up to 1.5mm <sup>2</sup>

### General

Operation	continuous
Weight	DC: 2.8kg, AC 3.1kg
Options	Tropicalized version, UL approval Case red (RAL3000)

## Order data

No. of article	Tension	Output	Current
DL112X.024.2*	20-28VDC	approx. 112dB(A),1m	Sounder 200mA / Beacon 250mA
DL112X.048.2*	35-60VDC	approx. 112dB(A),1m	Sounder 120mA / Beacon 175mA
DL112X.024.7*	24VAC	approx. 112dB(A),1m	Sounder 500mA / Beacon 300mA
DL112X.115.7*	115VAC	approx. 112dB(A),1m	Sounder 100mA / Beacon 70mA
DL112X.230.7*	230VAC	approx. 112dB(A),1m	Sounder 60mA / Beacon 35mA

**Colours of lenses:** 1=red, 2=amber, 3= yellow, 4=green, 5=blue, 7=clear

Modification of technical details without prior notice



**Comax**  
Signaltechnik

Comax Industrielle Signaltechnik AG, Thalstrasse 279, CH-4712 Laupersdorf/Schweiz  
Tel +41 32 617 31 41 E- mail@comax.ch Internet www.comax.ch