

# Installation/Anschluss Installation/Raccordement Installation/Connection

# DL105H

Installationsanleitung\_DL105H\_REV1\_20\_04\_2017

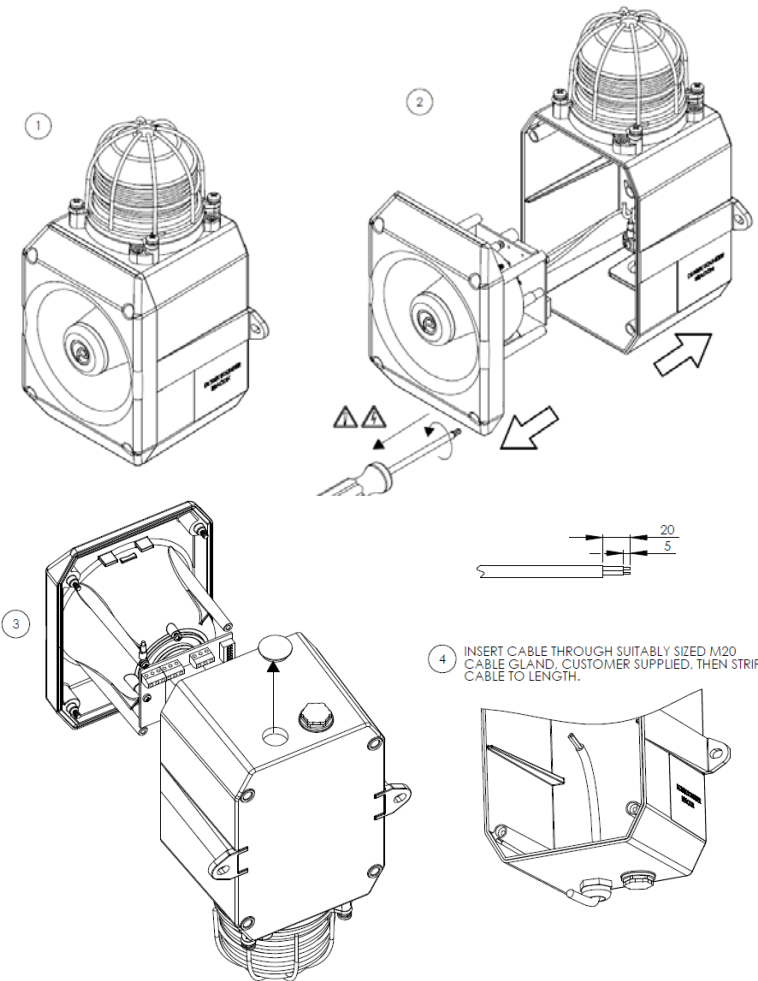

TERMINAL BLOCK	A/C INPUT	D/C INPUT
	⏏	
N/-	N~	-
L/+	L~	+
S2	SWITCH TO C	SWITCH TO -
S3	SWITCH TO C	SWITCH TO -

5 CONNECT CABLE AS SHOWN

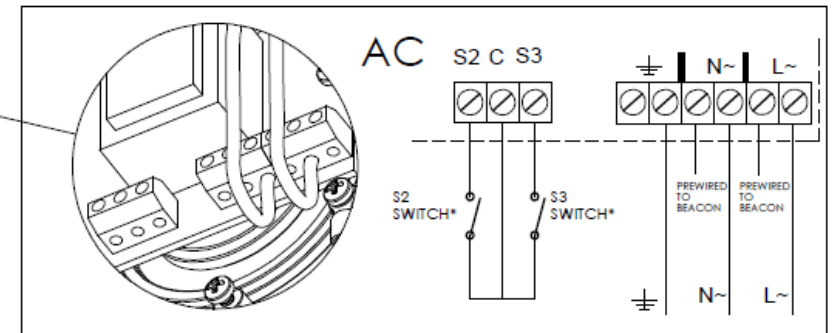
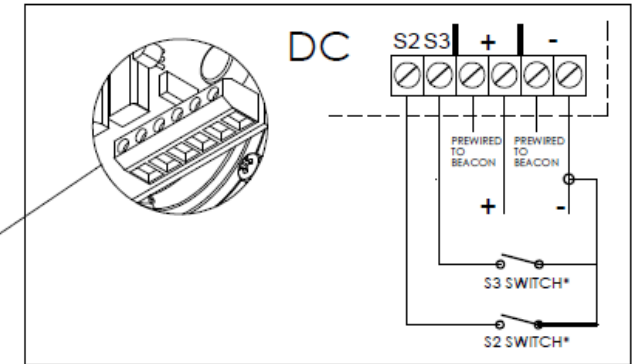
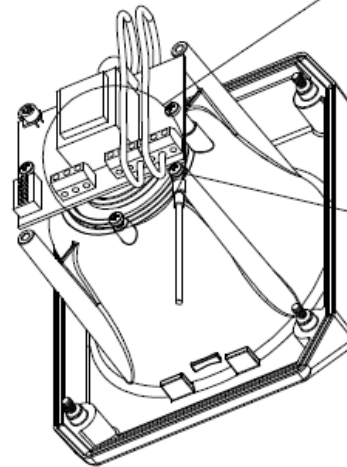

\*S2 & S3 Denote Stage 2 & Stage 3 respectively  
Stage switches are customer supplied

Dimensions in mm



**Lebensgefahr durch elektrischen Strom!** Dieses Gerät darf nur durch autorisierte Elektrofachkräfte und elektrotechnisch unterwiesene Personen montiert und angeschlossen werden.  
**Electric current! Danger to life!** Only authorized or instructed persons may assemble and install this device.  
**Tension électrique dangereuse!** Seuls les personnes averties sont autorisées d'assembler et d'installer ces produits.

Table 1 - Tone Selection						
STAGE 1	FREQUENCY DESCRIPTION	dB(A)@1m		Switch	Stage 2	Stage 3
TONE 1	340 Hz Continuous	102			TONE 2	TONE 5
TONE 2	800/1000Hz @ 0.25 sec Alternating	106			TONE 17	TONE 5
TONE 3	500/1200Hz @ 0.3Hz 0.5 sec Slow Whoop	106			TONE 2	TONE 5
TONE 4	800/1000Hz @ 1Hz Sw eeping	106			TONE 6	TONE 5
TONE 5	2400Hz Continuous	112			TONE 3	TONE 20
TONE 6	2400/2900Hz @ 7Hz Sw eeping	108			TONE 7	TONE 5
TONE 7	2400/2900Hz @ 1Hz Sw eeping	108			TONE 10	TONE 5
TONE 8	500/1200/500Hz @ 0.3Hz Sw eeping	106			TONE 2	TONE 5
TONE 9	1200/500Hz @ 1Hz - DIN / PFEER P.T.A.P.	106			TONE 15	TONE 2
TONE 10	2400/2900Hz @ 2Hz Alternating	110			TONE 7	TONE 5
TONE 11	1000Hz @ 1Hz Intermittent	106			TONE 2	TONE 5
TONE 12	800/1000Hz @ 0.875Hz Alternating	106			TONE 4	TONE 5
TONE 13	2400Hz @ 1Hz Intermittent	112			TONE 15	TONE 5
TONE 14	800Hz 0.25sec on, 1 sec off Intermittent	108			TONE 15	TONE 5
TONE 15	800Hz Continuous	108			TONE 2	TONE 5
TONE 16	660Hz 150mS on, 150mS off Intermittent	104			TONE 18	TONE 5
TONE 17	544Hz (100mS)/440Hz (400mS) - NF S 32-001	104			TONE 2	TONE 27
TONE 18	660Hz 1.8sec on, 1.8sec off Intermittent	104			TONE 2	TONE 5
TONE 19	1.4KHz-1.6KHz 1s, 1.6KHz-1.4KHz 0.5s -NFC48-265	106			TONE 2	TONE 5
TONE 20	660Hz Continuous	104			TONE 2	TONE 5
TONE 21	554Hz/440Hz @ 1Hz Alternating	104			TONE 2	TONE 5
TONE 22	544Hz @ 0.875 sec. Intermittent	104			TONE 2	TONE 5
TONE 23	800Hz @ 2Hz Intermittent	108			TONE 6	TONE 5
TONE 24	800/1000Hz @ 50Hz Sw eeping	108			TONE 29	TONE 5
TONE 25	2400/2900Hz @ 50Hz Sw eeping	108			TONE 29	TONE 5
TONE 26	Bell	100			TONE 2	TONE 15
TONE 27	554Hz Continuous	104			TONE 26	TONE 5
TONE 28	440Hz Continuous	103			TONE 2	TONE 5
TONE 29	800/1000Hz @ 7Hz Sw eeping	105			TONE 7	TONE 5
TONE 30	300Hz Continuous	100			TONE 2	TONE 5
TONE 31	660/1200Hz @ 1Hz Sw eeping	105			TONE 26	TONE 5
TONE 32	Two tone chime.	103			TONE 26	TONE 15

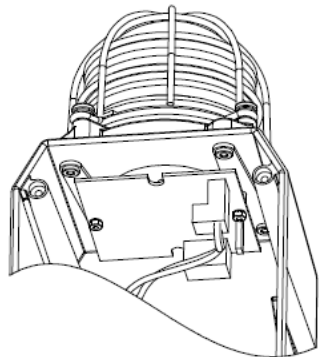

Header Pin settings for steady and flashing modes

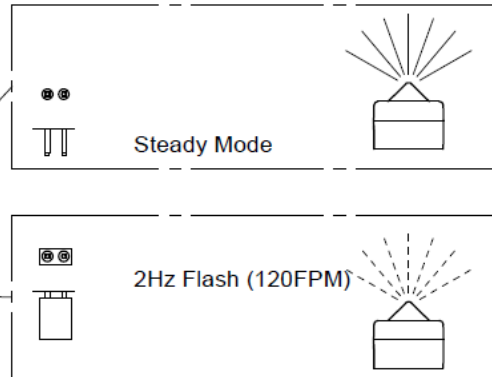

### DC CIRCUIT

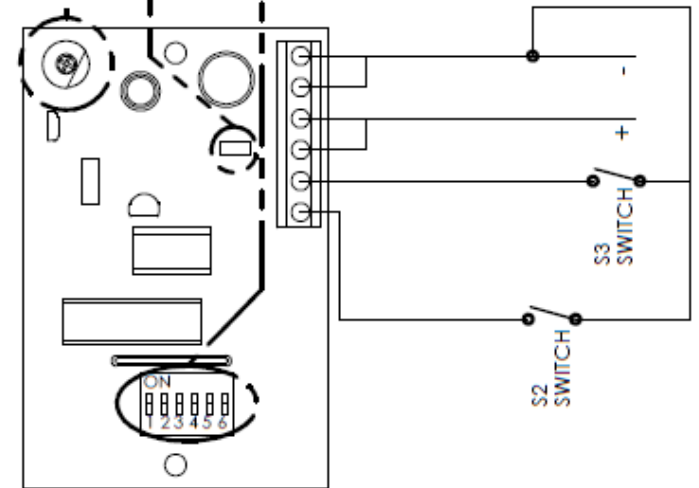

### AC CIRCUIT

