

# Panel mount strobe light STR1

**Comax**  
Signaltechnik

## General information

Small but efficient panel mount strobe light with a broad tension range. High degree of protection IP65.

For applications on control panels or on machines.



## Technical data

Dimensions	Ø 60mm x 65,5mm
Case	PC
-colour	black
Lens	PC
-colours	red, amber, yellow, green, blue, clear
Strobe intensity	1Joule
Frequency	0,75Hz
Output	37cd (clear dome)
Temperatur range	-25°C up to +50°C
Construction	Bayonet with anti-tamper locking screw
Operation	continuous
Installation	Panel mount, Ø 37mm
Connection	plug 0,5 - 1,5mm <sup>2</sup> (included with beacon)
Degree of protection	IP65 according to EN60529
Weight	93g

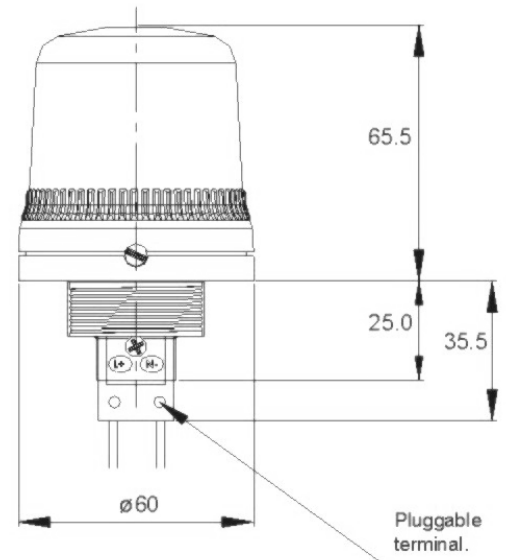

## Order data

No. of article	Nominal tension	Light output	Current consumption
STR1.024.3*	10-30VAC/VDC	1J	24VDC/82mA 24VAC/145mA
STR1.115.7*	115VAC 50/60Hz	1J	30mA
STR1.230.7*	230VAC 50/60Hz	1J	20mA

**Lens colours** 1 = red, 2 = amber, 3 = yellow, 4 = green, 5 = blue, 7 = clear

Technical modifications without prior notice



**Comax**  
Signaltechnik

Comax Industrielle Signaltechnik AG, Thalstrasse 279, CH-4712 Laupersdorf/Schweiz  
Tel +41 32 617 31 41 E- mail@comax.ch Internet www.comax.ch