

Signal bell WGS 3+4

General information

Materials and construction (weather-resistant) allow application for protected outdoor installation. Suitable for applications under difficult ambient conditions: e.g. ships, conveyor belts, cranes. Also effective, for example, as reliable rapid-percussion alarm in materials handling uses.

Technical data

Type	fast stroke
Case	aluminium die casting
Colour	dark grey
Dome	steel, Ø 250mm
Colour	light grey
System of protection	IP55 according to EN 60529
Duty cycle	continuous operation
Temperature range	-25°C to +60 °C
Cable:	
- gland	M20
- lead	surface mounting
Installation	dome downwards
Weight	approx. 3.3 kg

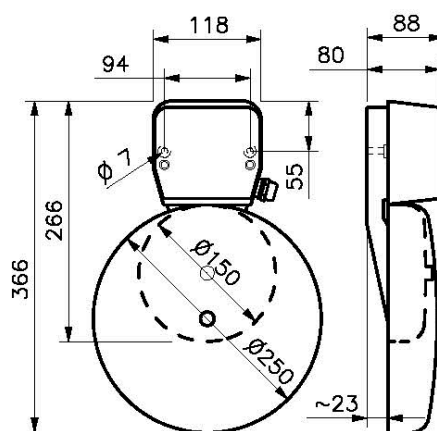

Order data

Item number	Rated voltage	Sound intensity level	Current consumption	Type
WGS3.024.1	24 VAC	approx. 110 dB(A), 1m	0.40 A	
WGS3.048.1	48 VAC	approx. 110 dB(A), 1m	0.20 A	
WGS3.060.1	60 VAC	approx. 110 dB(A), 1m	0.15 A	
WGS3.120.4	120 VAC 60Hz	approx. 110 dB(A), 1m	0.10 A	
WGS3.230.1	230 VAC	approx. 110 dB(A), 1m	0.05 A	
WGS3.230.1003	230 VAC	approx. 110 dB(A), 1m	0.05 A	with telephone relay
WGS4.024.2	24 VDC	approx. 110 dB(A), 1m	0.32 A	
WGS4.048.2	48 VDC	approx. 110 dB(A), 1m	0.20 A	

Other voltages on request

Special models upon request

- slow stroke
- single stroke
- stroke frequency upon customer specification
- sea-water resistant

Subject to change without prior notice

