

Small hooter with strobe light HPX1+2

Comax
Signaltechnik

General information

Electro-mechanical hooter with flare, combined with a xenon strobe light.

For universal applications.

Separate control of hooter and strobe light.



Technical data

Case	ABS, shock-resistant
Color	Grey (RAL 7035)
Lens	Polycarbonate, red or yellow
Flash	1 Joule, 1.4 Hz
Protection	IP43 according to EN 60529
Temperature range	-20°C bis +50°C
Operation	Continuous
Cable:	
-gland	Conductor up to 2,5 mm ²
Installation	Vertical, Sound outlet opening at bottom
Weight	Approx. 0.260 kg

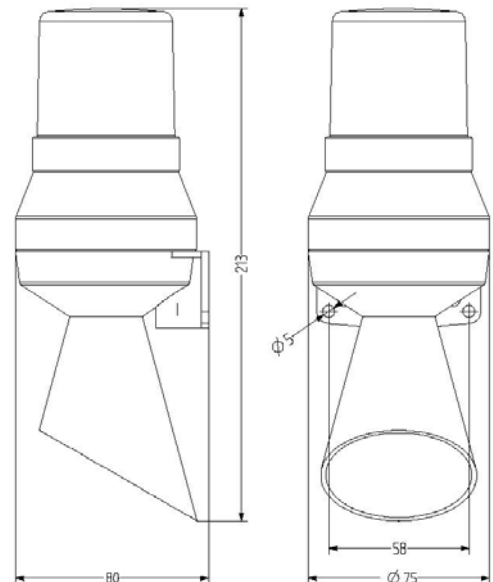

Order data

Item number	Rated voltage	Sound intensity level	Current consumption
HPX2.024.2*	24 VDC (+/- 10%)	ca. 92 dB(A), 1m	160 mA
HPX1.230.1*	230 VAC, 50 Hz (+/- 10%)	ca. 88 dB(A), 1m	35 mA

*Lens color 1 = red, 3 = yellow

Subject to change without prior notice



Comax
Signaltechnik

Comax Industrielle Signaltechnik AG, Thalstrasse 279, CH-4712 Laupersdorf/Schweiz
Tel +41-(0)32-617 31 41 E-mail mail@comax.ch Internet www.comax.ch