

# Electronic Sounder with Xenon Strobe Light AL112

**Comax**  
Signaltechnik



## General Information

Universal electronic sound generator with xenon flashing light. 64 different alarm tones and volume adjustable on the board. 4 tones can be controlled externally. Audible distance up to 125m. Automatic synchronisation of several units. Flashing light with 6 lens colours. Polarized diode for applications in supervised circuits. Degree of protection IP66.

Option: UL approval

## Technical data

Housing	ABS, shock resistant
-colour	red (RAL3000)
Lens	PC, shock resistant
-colour	red, amber, yellow, green, blue, clear
Flash intensity	5 Joule (approx. 250 cd / clear lens)
Light output	1Hz (DC devices 1.5Hz u. double-flash)
Degree of protection	IP66 acc. EN60529
Temperature	-40°C to +66°C
Relative humidity	95% at 20°C
Operation	Continuous operation
Tones	Choice of 64 tones (see tone table)
Connection	
-cable entry	2x M20 with stopping plugs Breakout hole (bottom)
-cable feed	Surface- or flush mounted
-connection	Terminals 0,5 – 1,5 mm <sup>2</sup>
Weight	DC: 0.950kg, AC: 1.200kg
Approval	VdS acc. EN54-3

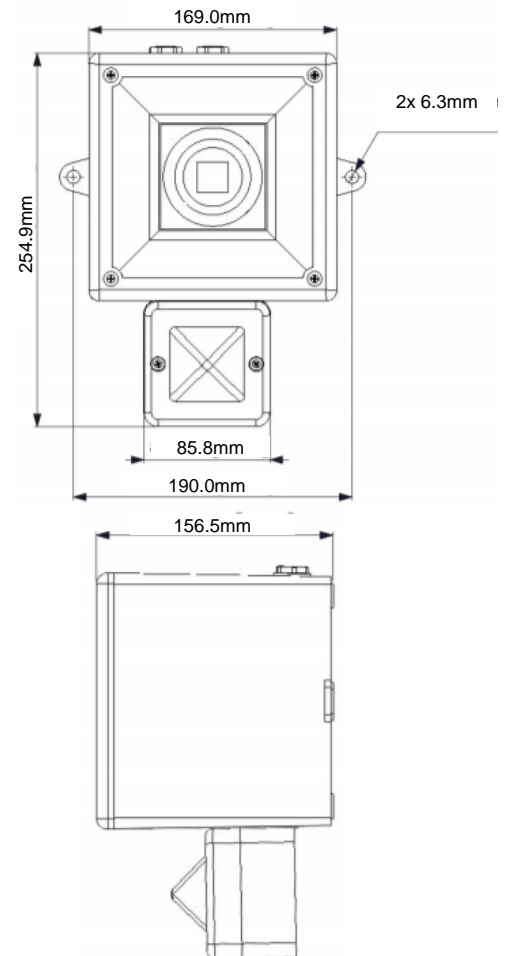
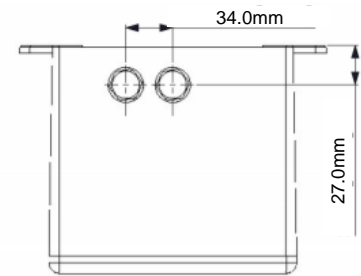

## Order data

Item number	Rated voltage	Sound level output	Current consumption Flash light / Sounder
AL112.012.2*	11.5-14VAC	nom, approx. 114dB(A), 1m	341mA / 280mA
AL112.024.2*	20-28VDC	nom, approx. 114dB(A), 1m	250mA / 225mA
AL112.048.2*	42-54VDC	nom, approx. 114dB(A), 1m	170mA / 122mA
AL112.115.7*	115VAC +/-10% 50/60Hz	nom, approx. 114dB(A), 1m	70mA / 100mA
AL112.230.7*	230VAC +/-10% 50/60Hz	nom, approx. 114dB(A), 1m	35mA / 64mA

other voltage versions on request

**Lens colours 1= red, 2= amber, 3= yellow, 4= green, 5= blue, 7= clear**

Subject to change without prior notice



**Comax**  
Signaltechnik

Comax Industrielle Signaltechnik AG, Thalstrasse 279, CH-4712 Laupersdorf/Schweiz  
Tel +41-(0)32-617 31 41 E-mail mail@comax.ch Internet www.comax.ch