

Installation/Anschluss Installation/Raccordement Installation/Connection

DL112X

Installationsanleitung_DL112X_REV2_20_04_2017

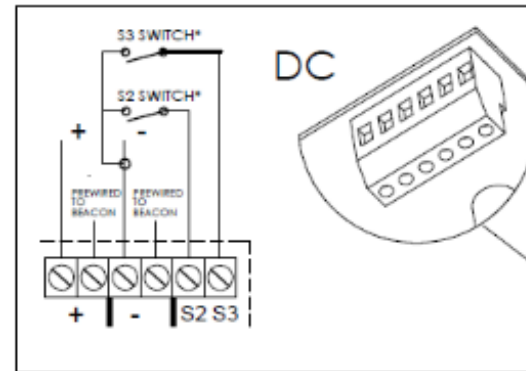
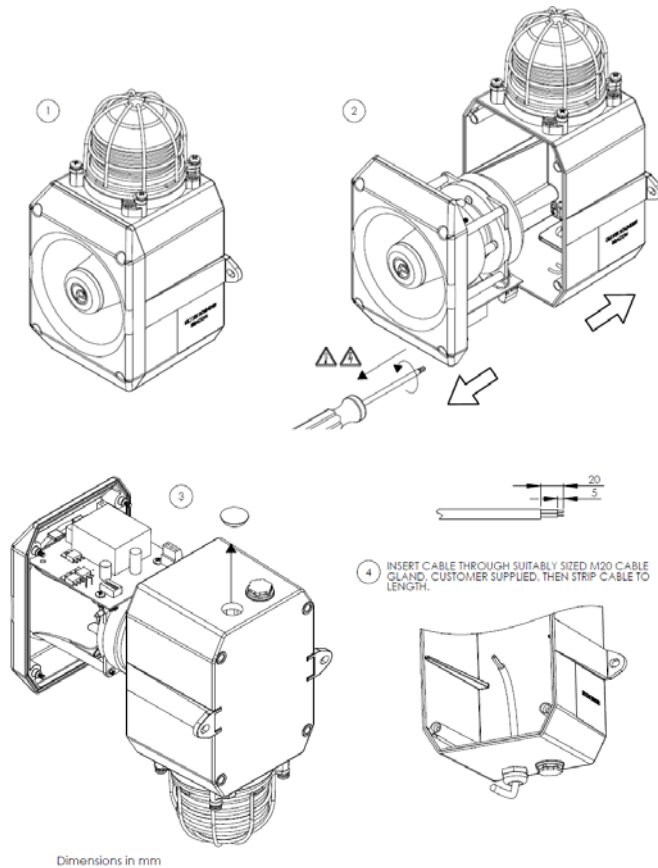

TERMINAL BLOCK	A/C INPUT	D/C INPUT
N/-	\perp	-
L/+	L~	+
S2	SWITCH TO C	SWITCH TO -
S3	SWITCH TO C	SWITCH TO -

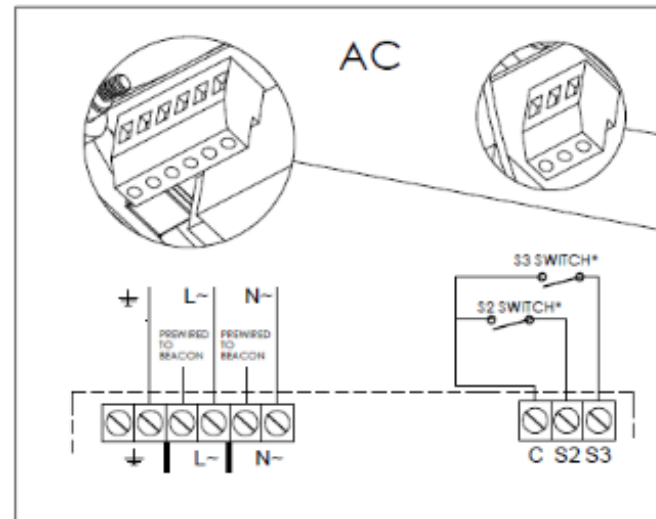

*S2 & S3 Denote Stage 2 & Stage 3 respectively
Stage switches are customer supplied

5 CONNECT CABLE AS SHOWN

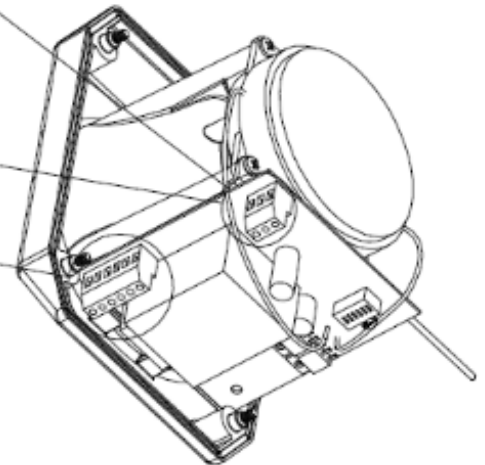

Lebensgefahr durch elektrischen Strom! Dieses Gerät darf nur durch autorisierte Elektrofachkräfte und elektrotechnisch unterwiesene Personen montiert und angeschlossen werden.
Electric current! Danger to life! Only authorized or instructed persons may assemble and install this device.
Tension électrique dangereuse! Seuls les personnes averties sont autorisées d'assembler et d'installer ces produits.

Table 1 - Tone Selection

STAGE 1	FREQUENCY DESCRIPTION	Waveform	Switch	Stage 2	Stage 3	Stage 4
Tone 1	340 Hz Continuous	[Sine wave]	[X]	Tone 2	Tone 5	Tone 29
Tone 2	800/1000Hz @ 0.25 sec Alternating	[Square wave]	[X]	Tone 17	Tone 5	Tone 29
Tone 3	500/1200Hz @ 0.3Hz 0.5 sec Slow Whoop	[Sine wave]	[X]	Tone 2	Tone 5	Tone 29
Tone 4	800/1000Hz @ 1Hz Sweeping	[Sine wave]	[X]	Tone 6	Tone 5	Tone 29
Tone 5	2400Hz Continuous	[Sine wave]	[X]	Tone 3	Tone 20	Tone 29
Tone 6	2400/2900Hz @ 7Hz Sweeping	[Sine wave]	[X]	Tone 7	Tone 5	Tone 29
Tone 7	2400/2900Hz @ 1Hz Sweeping	[Sine wave]	[X]	Tone 10	Tone 5	Tone 29
Tone 8	500/1200/500Hz @ 0.3Hz Sweeping	[Sine wave]	[X]	Tone 2	Tone 5	Tone 29
Tone 9	1200/500Hz @ 1Hz - DIN / PFEER P.T.A.P.	[Sine wave]	[X]	Tone 15	Tone 2	Tone 29
Tone 10	2400/2900Hz @ 2Hz Alternating	[Square wave]	[X]	Tone 7	Tone 5	Tone 29
Tone 11	1000Hz @ 1Hz Intermittent	[Dashed line]	[X]	Tone 2	Tone 5	Tone 29
Tone 12	800/1000Hz @ 0.875Hz Alternating	[Square wave]	[X]	Tone 4	Tone 5	Tone 29
Tone 13	2400Hz @ 1Hz Intermittent	[Dashed line]	[X]	Tone 15	Tone 5	Tone 29
Tone 14	800Hz 0.25sec on, 1 sec off Intermittent	[Dashed line]	[X]	Tone 4	Tone 5	Tone 29
Tone 15	800Hz Continuous	[Sine wave]	[X]	Tone 2	Tone 5	Tone 29
Tone 16	660Hz 150mS on, 150mS off Intermittent	[Dashed line]	[X]	Tone 18	Tone 5	Tone 29
Tone 17	544Hz (100mS)/440Hz (400mS) - NF S 32-001	[Square wave]	[X]	Tone 2	Tone 27	Tone 29
Tone 18	660Hz 1.8sec on, 1.8sec off Intermittent	[Dashed line]	[X]	Tone 2	Tone 5	Tone 29
Tone 19	1.4KHz-1.6KHz 1s, 1.6KHz-1.4KHz 0.5s -NFC48-265	[Sine wave]	[X]	Tone 2	Tone 5	Tone 29
Tone 20	660Hz Continuous	[Sine wave]	[X]	Tone 2	Tone 5	Tone 29
Tone 21	554Hz/440Hz @ 1Hz Alternating	[Square wave]	[X]	Tone 2	Tone 5	Tone 29
Tone 22	544Hz @ 0.875 sec. Intermittent	[Dashed line]	[X]	Tone 2	Tone 5	Tone 29
Tone 23	800Hz @ 2Hz Intermittent	[Dashed line]	[X]	Tone 6	Tone 5	Tone 29
Tone 24	800/1000Hz @ 50Hz Sweeping	[Sine wave]	[X]	Tone 29	Tone 5	Tone 29
Tone 25	2400/2900Hz @ 50Hz Sweeping	[Sine wave]	[X]	Tone 29	Tone 5	Tone 29
Tone 26	Bell	[Bell curve]	[X]	Tone 2	Tone 15	Tone 29
Tone 27	554Hz Continuous	[Sine wave]	[X]	Tone 26	Tone 5	Tone 29
Tone 28	440Hz Continuous	[Sine wave]	[X]	Tone 2	Tone 5	Tone 29
Tone 29	800/1000Hz @ 7Hz Sweeping	[Sine wave]	[X]	Tone 7	Tone 5	Tone 29
Tone 30	300Hz Continuous	[Sine wave]	[X]	Tone 2	Tone 5	Tone 29
Tone 31	660/1200Hz @ 1Hz Sweeping	[Sine wave]	[X]	Tone 26	Tone 5	Tone 29
Tone 32	Two tone chime.	[Square wave]	[X]	Tone 26	Tone 15	Tone 29
Tone 33	745Hz @ 1Hz Intermittent	[Dashed line]	[X]	Tone 2	Tone 5	Tone 29
Tone 34	1000 & 2000Hz @ 0.5 sec Alternating - Singapore	[Square wave]	[X]	Tone 38	Tone 45	Tone 29
Tone 35	420Hz @ 0.625 sec Australian Alert	[Dashed line]	[X]	Tone 36	Tone 5	Tone 29
Tone 36	500-1200Hz 3.75sec /0.25sec. Australian Evac.	[Sine wave]	[X]	Tone 35	Tone 5	Tone 29
Tone 37	1000Hz Continuous - PFEER Toxic Gas	[Sine wave]	[X]	Tone 9	Tone 45	Tone 29
Tone 38	2000Hz Continuous	[Sine wave]	[X]	Tone 34	Tone 45	Tone 29
Tone 39	800Hz 0.25sec on, 1 sec off Intermittent	[Dashed line]	[X]	Tone 23	Tone 17	Tone 29
Tone 40	544Hz (100mS)/440Hz (400mS) - NF S 32-001	[Square wave]	[X]	Tone 31	Tone 27	Tone 29
Tone 41	Motor Siren - slow rise to 1200 Hz	[Sine wave]	[X]	Tone 2	Tone 5	Tone 29
Tone 42	Motor Siren - slow rise to 800 Hz	[Sine wave]	[X]	Tone 2	Tone 5	Tone 29
Tone 43	1200 Hz Continuous	[Sine wave]	[X]	Tone 2	Tone 5	Tone 29
Tone 44	Motor Siren - slow rise to 2400 Hz	[Sine wave]	[X]	Tone 2	Tone 5	Tone 29
Tone 45	1KHz 1s on, 1s off Intermittent - PFEER Gen. Alarm	[Dashed line]	[X]	Tone 38	Tone 34	Tone 29

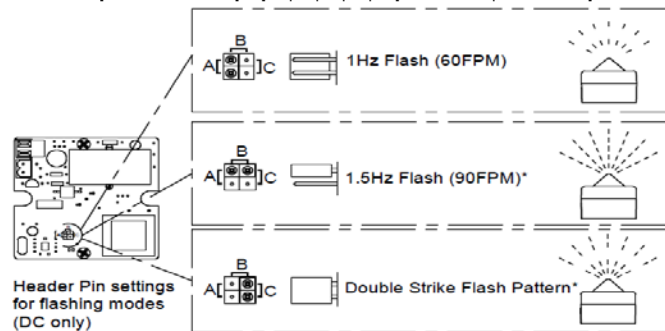
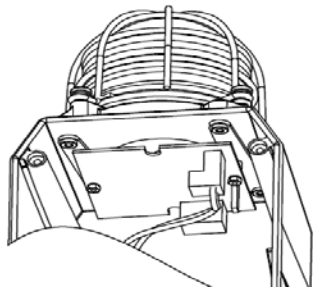

AC CIRCUIT

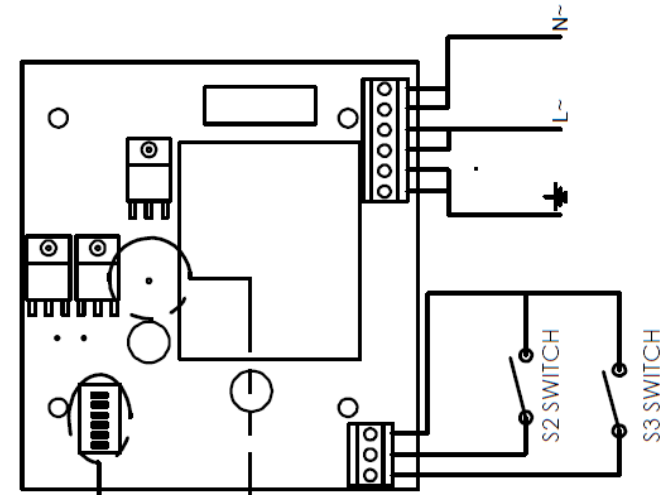

DC CIRCUIT

