



500 Series Alarms

ECCO's most compact and popular line of back-up alarms, the 500 Series provides a cost-effective warning solution with ECCO quality and reliability. A glass-filled nylon housing with epoxy-encapsulated electronics provide exceptional durability and protection against moisture, dust and vibration. ECCO's 500 Series Smart Alarm® measures ambient noise and adjusts sound levels, creating a volume that is safe without being annoying or contributing to noise pollution. Smart Alarms eliminate the need for constant manual adjustment.

Models

PART NO.	VOLTAGE	dB(A)	AMPS
505-001	12/24V	87	0.1A
505-000	12/24V	87	0.1A
580-001	12-80V	87	0.1A
580-000	12-80V	87	0.1A
520-001	12/24V	97	0.2A
520-000	12/24V	97	0.2A
585-001	12-48V	97	0.1A
585-000	12-48V	97	0.1A
530-001	12/24V	102	0.9A
530-000	12/24V	102	0.9A
520-004	12/24V	97-0	0.2A
515-004	12/24V	90-0	0.2A
515-002	12/24V	90-0	0.2A
515-003	12/24V	90-78	0.1A
520-003	12/24V	97-87	0.1A
950-001	12/24V	82-102	0.4A
950-000	12/24V	82-102	0.4A
951-001	12-48V	77-97	0.2A
951-000	12-48V	77-97	0.2A

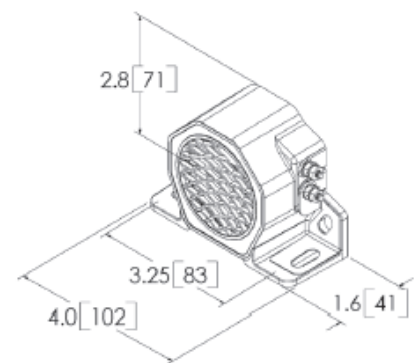

Features and Benefits

- Compact size and universal mounting bracket maximizes location options
- Self grounding
- Sealed in epoxy for protection against dust, moisture, and vibration
- Temperature Range: -40°C to +85°C

Alarm Specifications

Connection: 8-32 uni stud connection
 Recommended mounting bolt: 1/4" Grade 5
 Recommended washer: 1/4" Type A, Series N or W

