

Installation/Anschluss Installation/Raccordement Installation/Connection

Installationsanleitung_A100T_d_e_f_REV0_31_05_2022

A100T

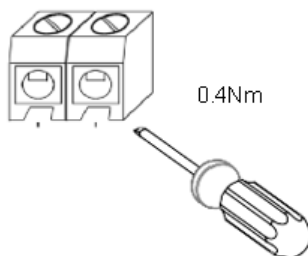
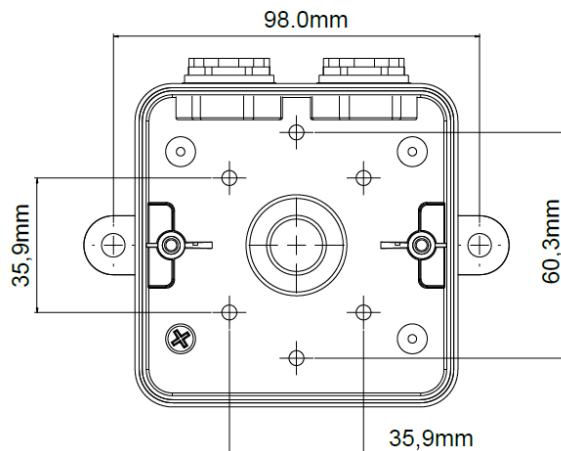
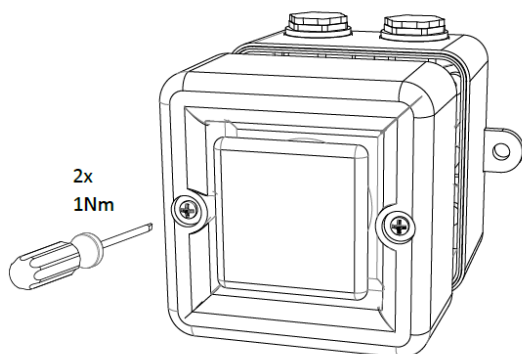
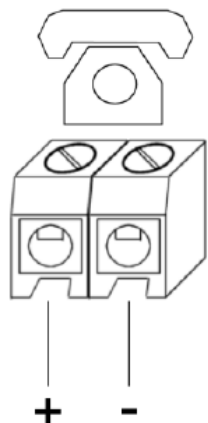

VOLUME CONTROL

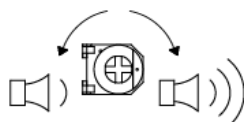

TONE TABLE

Tone	Description		
Tone 1	Siren Tone		108dB(A)
Tone 2	Alternating tone		104dB(A)
Tone 3	Sweeping tone		106dB(A)

dB(A) output figures: +/-3dB(A)

Achtung / attention / attention

Bei Kabeleinführung durch die Ausbruchsstelle im Gehäuseboden bei der Montage die mitgelieferte Flachdichtung verwenden um den Schutzgrad IP66 sicherzustellen.

En cas d'entrée de câble par l'ouverture dans le fond du boîtier, utiliser le joint plat fourni lors du montage pour garantir le degré de protection IP66.

In case of cable entry through the break-out point in the enclosure base, use the supplied flat gasket during installation to ensure the IP66 degree of protection.

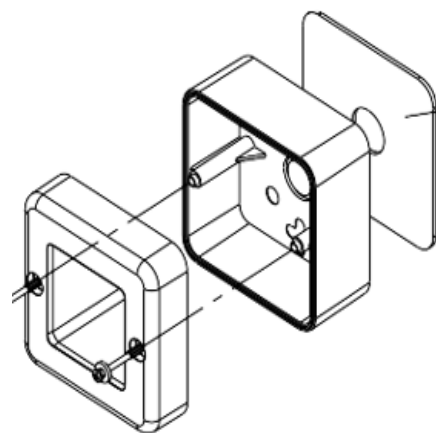

Lebensgefahr durch elektrischen Strom!

Dieses Gerät darf nur durch autorisierte Elektrofachkräfte und elektrotechnisch unterwiesene Personen montiert und angeschlossen werden.

Electric current! Danger to life!

Only authorized or instructed persons may assemble and install this device.

Tension électrique dangereuse!

Seuls les personnes averties sont autorisées d'assembler et d'installer ces produits.