

Installation/Anschluss  
 Installation/Raccordement  
 Installation/Connection

# A105

- -40°C to +66°C (-40°F to 151°F)
- Type 4 / 4X / 3R / 13, IP66
- 0.75Kg (1.65lb)
- CE, A105.024.2 CPR compliant, All units UL Listed

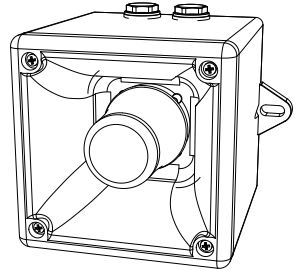

Unit Type Code	Nominal Voltage	Voltage Range	Nominal Current*	Nominal SPL	Max SPL	Average SPL
A105.024.2	12 V dc	10-60Vdc	17mA	105.3dB(A) Tone 44 @ 1m	110.9dB(A) Tone 4 @ 1m	105.2dB(A) All tones @1m
	24V dc		33.5mA			
	48V dc		113mA			
A105.230.7	48V ac	24 - 260Vac / 60-260Vdc	42mA	105.3dB(A) Tone 44 @ 1m	110.9dB(A) Tone 4 @ 1m	105.2dB(A) All tones @1m
	115V ac		25mA			
	230V ac		17mA			

\*Nominal current at nominal voltage, Tone 1

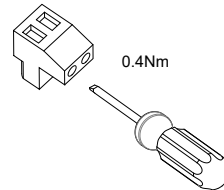
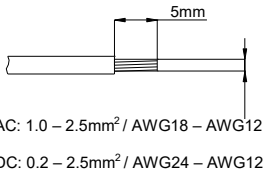

Attention: Installation must be carried out by an electrician in compliance with the latest codes and regulations.  
 Attention: L'installation doit être effectuée par un électricien conformément aux derniers codes et réglementations.  
 Achtung: Die Installation muss von einem Elektriker gemäß den neuesten Vorschriften und Bestimmungen durchgeführt werden.



Attention: Disconnect from power source before installation or service to prevent electric shock  
 Attention: Débranchez-le de la source d'alimentation avant l'installation ou l'entretien pour éviter tout choc électrique.  
 Achtung: Vor Installation oder Wartung von der Stromquelle trennen, um einen Stromschlag zu vermeiden.

# AC

(See D218-06-005)

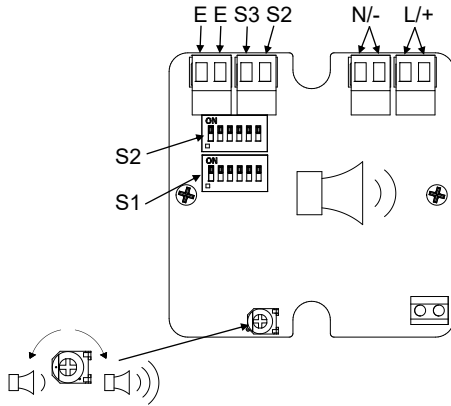

# DC

(See D218-06-001)

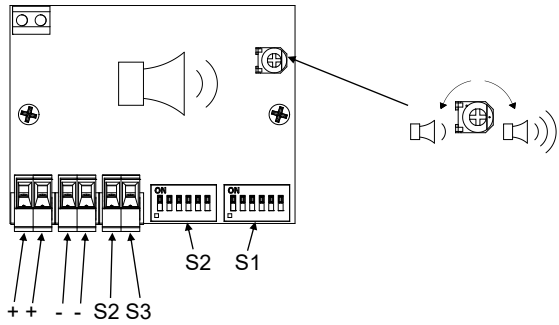

(AC & DC, See D221-95-001)

Default = S2 - Tone 1

Default = S1 - Tone 44

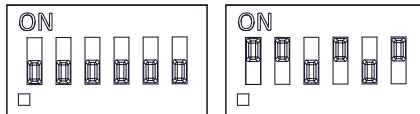

(ON = 1, OFF = 0)

INSTRUCTION & SERVICE MANUAL  
A105

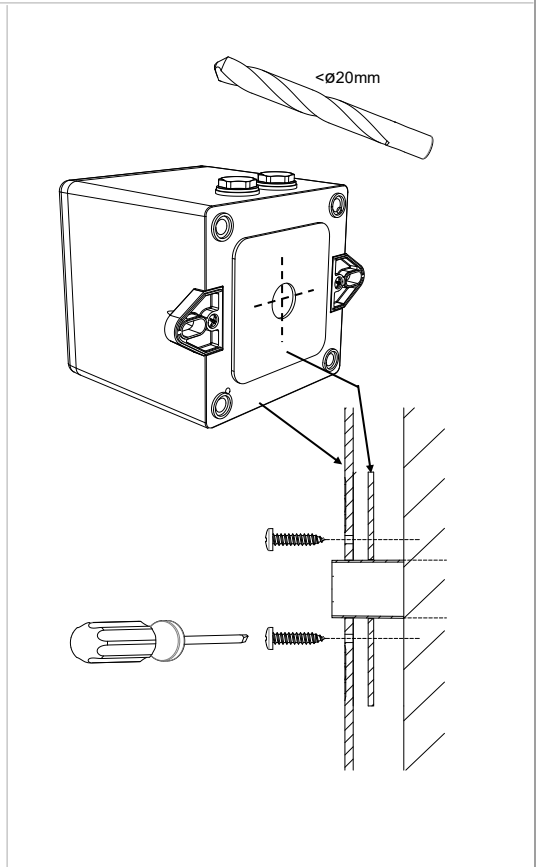
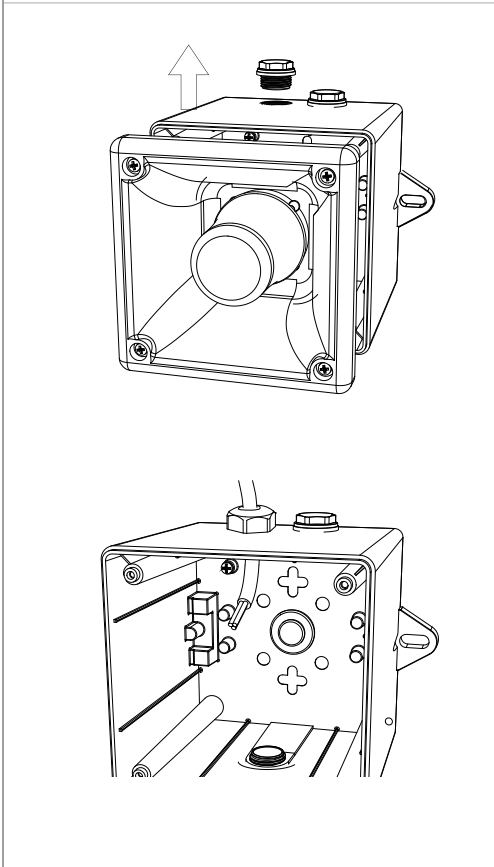
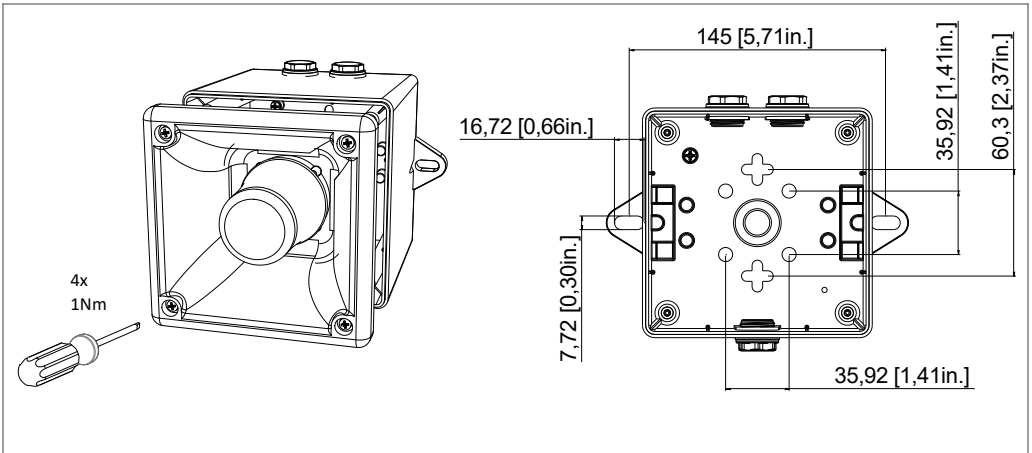

### Construction Product Regulation

- A105.024.2 is compliant to EN54-3:2001+A1+A2
- Alarm devices – Sounder for use in fire detection and fire alarm systems installed in and around buildings
- Type 4 / 4X / 3R / 13, IP66, Independently tested to EN60529:1991, (IP33C Compliant to EN54-3)
- Type B Product, For Indoor & Outdoor use
- Observe Precautions for handling electrostatic devices
- -25°C to +55°C compliant to EN54-3
- Cable Glands must be suitably sealed and meet minimum IP33 for EN54-3 applications
- Storage Temperature: -40°C to +70°C
- Maintenance – None
- Mounting - Units can be mounted using the 2-off  $\varnothing 7$ mm holes or through the back of the housing using the supplied gasket seal

Order Code: A105.024.2  
 Voltage Range: 18-60Vdc  
 Nominal Voltage: 24Vdc / 48Vdc  
 Max Current: 125mA @ 60Vdc  
 DP-2821-CPR-0107



### Approved Tones for EN54-3 Applications:

- (Alternating Tone) 800/1000Hz @ 2Hz Alternating Tone 44
- (Rising Tone) 500/1200Hz @ 0.26Hz (3.3s on, 0.5s off) Tone 8
- (Fainting Tone) 1200/500Hz @ 1Hz Tone 2
- (Continuous Tone) 800Hz Tone 21
- (Pulsed Tone) 660Hz (150mS on, 150mS off) Tone 31
- (Alternating Tone) 544Hz(100mS)/440Hz (400mS) Tone 5

#### A105.024.2 @ 1m

Angle	Horizontal Sound Output Max Voltage (60 Vdc) LAFmax,T dB(A)						Horizontal Sound Output Min Voltage (18 Vdc) LAFmax,T dB(A)					
	Tone 44	Tone 8	Tone 2	Tone 21	Tone 31	Tone 5	Tone 44	Tone 8	Tone 2	Tone 21	Tone 31	Tone 5
15°	93.9	94.6	93.7	94	91	91.8	90.8	91.2	90.5	90.9	88	89.1
45°	99.6	101.4	100.1	99.7	96.6	98.2	96.5	98.3	96.9	96.6	93.5	95.7
75°	102.5	103.9	103.5	102.6	102	100.6	100	101.1	100.6	100.1	98.7	98
105°	102.5	103.9	103.4	102.7	102	100.6	100	101.1	100.6	100.3	98.8	98.2
135°	99.5	101.4	100.1	99.7	96.4	98.1	96.4	98.2	96.9	96.6	93.5	95.5
165°	94.1	94.8	93.7	94.1	90.6	91.8	91.1	91.5	90.5	91.1	87.6	89.2
Angle	Vertical Sound Output Max Voltage (60 Vdc) LAFmax,T dB(A)						Vertical Sound Output Min Voltage (18 Vdc) LAFmax,T dB(A)					
	Tone 44	Tone 8	Tone 2	Tone 21	Tone 31	Tone 5	Tone 44	Tone 8	Tone 2	Tone 21	Tone 31	Tone 5
15°	93.8	94.7	93.5	94.3	90.2	91.8	90.7	91.5	90.2	91.2	87.3	89.2
45°	99.6	101.4	100.1	100	96.4	98.3	96.5	98.4	97	96.9	93.4	95.7
75°	103	104.2	103.7	103.2	101.5	100.6	99.8	101.1	100.5	100.1	98.5	98.1
105°	102.6	104.2	103.4	102.6	101.8	100.5	100	101	100.6	100	99	98
135°	99.5	101.4	100.1	99.8	96.4	98.3	96.3	98.2	97	96.6	93.5	95.7
165°	94.3	94.5	93.6	94.6	89.8	91.6	91.2	91.2	90.4	91.5	96.8	88.8

# INSTRUCTION & SERVICE MANUAL

## A105

- All models are approved for use as Audible Signal Appliance for use as General Signaling: UL464A & CSA C22.2 No 205-17
- Type 4 / 4X / 3R / 13, IP66
- -40°C to +66°C / -40°C to +151°F  
 General Signaling Canada:  
 A105.024.2: -40°C to +55°C / -40°F to +131°F  
 A105.230.7: -40°C to +40°C / -40°F to +104°F



- To maintain Ingress Protection, cable entries must be fitted with suitably rated cable glands or stopping plugs
- EOL Monitoring (DC Only): End of Line Devices may be fitted between the +ve & -ve terminals of the PCBA. Please ensure that the device legs meet the wire size range stated for the connection terminals and are fitted correctly in order to avoid a short. Refer to the compatible control panel specification for EOL device values and ratings.

Model	Nominal Voltage	Voltage Range	Nominal Operating Current <sup>#</sup>	Max Operating RMS*
A105.024.2	12V dc	10 - 60V ac	17mA	125mA
	24V dc		33.5mA	
	48V dc		113mA	
A105.230.7	48V ac	24 - 260V ac 50/60Hz / 60-260V dc	42mA	42.5mA
	115V ac		25mA	
	230V ac		17mA	

\*Max Operating current for worst-case input voltage; #Nominal current at nominal voltage and Tone 12

The units have been tested and approved to DNVGL-CG-0339 & EN54-3:2014 incl. A1:2019 for the installation on ships in the following locations:

Temperature: A, B, C & D (Machinery spaces, control rooms, accommodation, bridge, inside cubicles, desks, etc..., pump rooms, holds, rooms with no heating, Open deck, masts)

Humidity: A & B (All locations)

Vibration: A (Bulkheads, Beams, Deck, Bridge)

EMC: A (All locations except Bridge & open deck)

Enclosure: A, B & C, IP66 (Control rooms, accommodation, bridge, engine room, open deck masts, below floor plates in engine room)

The units comply with Solas 74 Chapter II-2, Regulation 7 & Chapter X, Regulation 3 for installation on ships in the following locations:

Temperature: D (Location -25° to +70°C)

Vibration: A (General Applications)

EMC: A (General Power Distribution Zone)

Enclosure: IP66, Salt mist

Stage 1 Set DIP SW 1 Tone No.	Tone Description	Tone Visual	Stage 1 & 2 DIP SW 1/2 Settings 1 2 3 4 5 6	Stage 3 Set DIP SW 1 (S3)	Stage 4 Set DIP SW 1 (S2 + S3)
1	1000Hz PFEER Toxic Gas		0 0 0 0 0 0	2	44
2	1200/500Hz @ 1Hz DIN /PFEER P.T.A.P.		1 0 0 0 0 0	3	44
3	1000Hz @ 0.5Hz(1s on, 1s off) PFEER Gen. Alarm		0 1 0 0 0 0	2	44
4	1.4KHz-1.6KHz 1s, 1.6KHz-1.4KHz 0.5s NF C 48-265		1 1 0 0 0 0	24	1
5	544Hz(100mS)/440Hz (400mS) NF S 32-001		0 0 1 0 0 0	19	1
6	1500/500Hz - (0.5s on, 0.5s off) x3 + 1s gap AS4428		1 0 1 0 0 0	44	1
7	500-1500Hz Sweeping 2 sec on 1 sec off AS4428		0 1 1 0 0 0	44	1
8	500/1200Hz @ 0.26Hz (3.3son, 0.5s off) Netherlands - NEN 2575		1 1 1 0 0 0	24	35
9	1000Hz (1s on, 1s off)x7 + (7s on, 1s off) IMO Code 1a		0 0 0 1 0 0	34	1
10	1000Hz (1s on, 1s off)x7 + (7s on, 1s off) IMO Code 1a		1 0 0 1 0 0	34	1
11	420Hz(0.5s on, 0.5s off)x3 + 1s gap ISO 8201 Temporal Pattern		0 1 0 1 0 0	1	8
12	1000Hz(0.5s on, 0.5s off)x3 + 1s gap ISO 8201 Temporal Pattern		1 1 0 1 0 0	1	8
13	422/775Hz - (0.85 on, 0.5 off) x3 + 1s gap NFPA - Temporal Coded		0 0 1 1 0 0	1	8
14	1000/2000Hz @ 1Hz Singapore		1 0 1 1 0 0	3	35
15	300Hz Continuous (f=300)		0 1 1 1 0 0	24	1
16	440Hz Continuous (f=440)		1 1 1 1 0 0	24	1
17	470Hz Continuous (f=470)		0 0 0 0 1 0	24	8
18	500Hz Continuous IMO code 2 (Low) (f=500)		1 0 0 0 1 0	24	8
19	554Hz Continuous (f=554)		0 1 0 0 1 0	24	8
20	660Hz Continuous (f=660)		1 1 0 0 1 0	24	35
21	800Hz IMO code 2 (High) (f=800)		0 1 0 1 0 0	24	35
22	1200Hz Continuous (f=1200)		1 0 1 0 1 0	24	35
23	2000Hz Continuous (f=2000)		0 1 1 0 1 0	3	35
24	2400Hz Continuous (f=2400)		1 1 1 0 1 0	20	35
25	440Hz @0.83Hz (50 cycles/minute) Intermittent (f=440, a=0.6, b=0.6)		0 0 0 1 1 0	44	8
26	470Hz @0.9Hz - 1.1s Intermittent (f=470, a=0.55, b=0.55)		1 0 0 1 1 0	44	8
27	470Hz @5Hz - (5 cycles/second) Intermittent (f=470, a=0.1, b=0.1)		0 1 0 1 1 0	44	8
28	544Hz @ 1.14Hz - 0.875s Intermittent (f=470, a=0.43, b=0.44)		1 1 0 1 1 0	24	8
29	655Hz @ 0.875Hz Intermittent (f=655, a=0.57, b=0.57)		0 0 1 1 1 0	24	8
30	660Hz @0.28Hz - 1.8sec on, 1.8sec off Intermittent (f=660, a=1.8, b=1.8)		1 0 1 1 1 0	24	8
31	660Hz @3.34Hz - 150mS on, 150mS off Intermittent (f=660, a=0.15, b=0.15)		0 1 1 1 1 0	24	8
32	745Hz @ 1Hz Intermittent (f=745, a=0.5, b=0.5)		1 1 1 1 1 0	24	8
33	800Hz - 0.25sec on, 1 sec off Intermittent (f=800, a=0.25, b=1)		0 0 0 0 0 1	24	8
34	800Hz @ 2Hz IMO code 3.a (High) Intermittent (f=800, a=0.25, b=0.25)		1 0 0 0 0 1	24	19
35	1000Hz @ 1Hz Intermittent (f=1000, a=0.5, b=0.5)		0 1 0 0 0 1	24	19
36	2400Hz @ 1Hz Intermittent (f=2400, a=0.5, b=0.5)		1 1 0 0 0 1	24	19
37	2900Hz @ 5Hz Intermittent (f=2900, a=0.1, b=0.1)		0 0 1 0 0 1	24	19
38	363/518Hz @ 1Hz Alternating (f=363, f1=518, a=0.1)		1 0 1 0 0 1	8	19
39	450/500Hz @ 2Hz Alternating (f=450, f1=500, a=0.25)		0 1 1 0 0 1	8	19
40	554/440Hz @ 1Hz Alternating (f=440, f1=554, a=0.5)		1 1 1 0 0 1	24	19
41	554/440Hz @ 0.625Hz Alternating (f=440, f1=554, a=0.8)		0 0 0 1 0 1	8	19
42	561/760Hz @0.83Hz (50 cycles/minute) Alternating (f=561, f1=760, a=0.6)		1 0 0 1 0 1	8	19
43	780/600Hz @ 0.96Hz Alternating (f=600, f1=780, a=0.52)		0 1 0 1 0 1	8	19
44	800/1000Hz @ 2Hz Alternating (f=800, f1=1000, a=0.25)		1 1 0 1 0 1	24	19
45	970/800Hz @ 2Hz Alternating (f=800, f1=970, a=0.25)		0 0 1 1 0 1	8	19
46	800/1000Hz @ 0.875Hz Alternating (f=800, f1=1000, a=0.57)		1 0 1 1 0 1	24	19
47	2400/2900Hz @ 2Hz Alternating (f=2400, f1=2900, a=0.25)		0 1 1 1 0 1	24	19
48	500/1200Hz @ 0.3Hz Sweeping (f=500, f1=1200, a=3.34)		1 1 1 1 0 1	24	12
49	560/1055Hz @ 0.18Hz Sweeping (f=560, f1=1055, a=5.47)		0 0 0 0 1 1	24	12
50	560/1055Hz @ 3.3Hz Sweeping (f=560, f1=1055, a=0.3)		1 0 0 0 1 1	24	12
51	600/1250Hz @ 0.125Hz Sweeping (f=600, f1=1250, a=8)		0 1 0 0 1 1	24	12
52	660/1200Hz @ 1Hz Sweeping (f=660, f1=1200, a=1)		1 1 0 0 1 1	24	12
53	800/1000Hz @ 1Hz Sweeping (f=800, f1=1000, a=1)		0 1 0 0 1 1	24	12
54	800/1000Hz @ 7Hz Sweeping (f=800, f1=1000, a=0.14)		1 0 1 0 1 1	24	12
55	800/1000Hz @ 50Hz Sweeping (f=800, f1=1000, a=0.02)		0 1 0 1 1 1	24	12
56	2400/2900Hz @ 7Hz Sweeping (f=2400, f1=2900, a=0.14)		1 1 1 0 1 1	24	12
57	2400/2900Hz @ 1Hz Sweeping (f=2400, f1=2900, a=1)		0 0 0 1 1 1	24	12
58	2400/2900Hz @ 50Hz Sweeping (f=2400, f1=2900, a=0.02)		1 0 0 1 1 1	24	12
59	2500/3000Hz @ 2Hz Sweeping (f=2500, f1=3000, a=0.5)		0 1 0 1 1 1	24	12
60	2500/3000Hz @ 7.7Hz Sweeping (f=2500, f1=3000, a=0.13)		1 1 0 1 1 1	24	12
61	800Hz Motor Siren (f=800, a=1.6)		0 0 1 1 1 1	24	12
62	1200Hz Motor Siren (f=1200, a=2)		1 0 1 1 1 1	24	12
63	2400Hz Motor Siren (f=2400, a=1.7)		0 1 1 1 1 1	24	12
64	Simulated Bell		1 1 1 1 1 1	21	12

# FIRE INSTRUCTION & SERVICE MANUAL

## A105UL464 / CAN/ULC-S525 Model: A105.024.2



Attention: Installation must be carried out by an electrician in compliance with the National Electrical Code, NFPA 70, and the National Fire Alarm Signaling Code, NFPA 72 or CSA 22.1 Canadian Electrical Code, Part 1, Safety Standard for Electrical Installations, Section 32. / L'installation doit exclusivement être réalisée par du personnel qualifié, conformément au code national d'électricité américain, NFPA 70, et le code national d'alarme incendie et de signalisation NFPA 72 ou CSA 22.1 Code canadien de l'électricité, première partie, norme de sécurité relative aux installations électriques, Section 32



Attention: Disconnect from power source before installation or service to prevent electric shock / Débranchez-le de la source d'alimentation avant l'installation ou l'entretien pour éviter tout choc électrique.



Attention: Do not paint / Ne pas Peinturer

- 40°C to +66°C / -40°F to +151°F
- Units can be mounted using the 2-off  $\varnothing$ 7mm holes in the mounting lugs or through the back of the housing using the supplied gasket seal.
- A105.024.2 is approved for use as an audible signal appliance for fire alarm use – Public Mode (UL464 & CAN/ULC-S525) and produces a minimum sound pressure level of US: 79.97dB(A) ; CA: 91.2dB(A) at 10 feet (figures @ worst case 10Vdc).
- A105.024.2 produces a minimum sound pressure level of US: 88.8dB(A) ; CA: 99.8dB(A) at 10 feet (@ 24Vdc)
- For Fire Alarm applications, the Sounder Volume must be at the highest setting. (see volume control section). For fire alarm use, Tone 12 as shown below must be selected:

Stage 1 Set DIP SW 1 Tone No.	Tone Description	Tone Visual	Stage 1 & 2 DIP SW 1/2 Settings 1 2 3 4 5 6	Stage 3 Set DIP SW 1 (S3)	Stage 4 Set DIP SW 1 (S2 + S3)
12	1000Hz(0.5s on, 0.5s off)x3 + 1s gap ISO 8201 Temporal Pattern		1 1 0 1 0 0	1	8

- Connection Terminals: Pluggable  
AC: 1.0 - 2.5mm<sup>2</sup> / AWG18 - AWG12  
DC: 0.2 - 2.5mm<sup>2</sup> / AWG24 - AWG12
- Terminal Tightening torque 0.4Nm
- To maintain Ingress Protection, cable entries must be fitted with suitably rated cable glands or stopping plugs
- Units can be located indoor or outdoor wet use, wall or ceiling mounted and there are no limitations on orientation
- Factory finishes are not intended to be modified

### Surge Current Ratings for use in fire alarm systems

Model	Nominal Voltage	Voltage Range	Initial Peak	Initial RMS
A105.024.2	24V dc	10 - 60V dc	298mA	56.4mA

### A105.024.2 Sounder Directional Characteristics for Canadian Fire CAN/ULC-S525 at 10 feet

Horizontal Axis				Vertical Axis			
Angle	OSPL	Angle	OSPL	Angle	OSPL	Angle	OSPL
Ref.90°	101 dB(A)	Ref. 90°	101 dB(A)	Ref. 90°	100.9 dB(A)	Ref. 90°	100.9 dB(A)
113°	-3 dB(A)	67°	-3 dB(A)	113.5°	-3 dB(A)	64°	-3 dB(A)
125°/147°	-6 dB(A)	52°	-6 dB(A)	130°/148°	-6 dB(A)	47°	-6 dB(A)
180°	86.1 dB(A)	0°	86.1 dB(A)	180°	86.5 dB(A)	0°	86.1 dB(A)

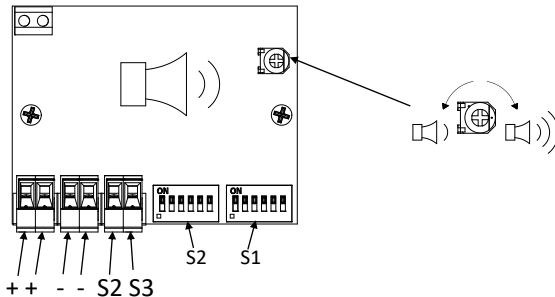

ISSUE MOD No		REASON - INITIAL - DATE
A		INTRODUCTION RSK - 11/03/2021

OPTIONAL LINE MONITORING RESISTOR, CUSTOMER SUPPLIED.  
RECOMMENDED MINIMUM VALUES:  
RESISTOR VALUE = 100 OHMS OR 140 MIN. 0.5W MIN.  
25V MAX. SYSTEM = 4700 MIN. 2W MIN OR 2.4K0 MIN. 0.5W MIN

Single Stage Configuration	Config.: 1a	Two Stage Configuration	Config.: 1b	Three/Four Stage Configuration	Config.: 1c
----------------------------	-------------	-------------------------	-------------	--------------------------------	-------------

Line Monitoring  
Stage 1: Apply Power to Stage 1 +ve & Stage 1 -ve  
Common Positive  
Stage 1: Apply Power to Common +ve & Stage 1 -ve & connect  
Stage 2: Apply Power to Common +ve & Stage 1 -ve & Stage 2 -ve to Stage 1 -ve  
Common Positive  
Stage 1: Apply Power to Common +ve & Stage 1 -ve  
Stage 2: Apply Power to Common +ve & Stage 1 -ve & connect  
Stage 2 -ve to Stage 1 -ve  
Stage 3: Apply Power to Common +ve & Stage 1 -ve & connect  
Stage 3 -ve to Stage 1 -ve  
Stage 4: Apply Power to Common +ve & Stage 1 -ve & connect  
Stage 2 -ve & Stage 3 -ve to Stage 1 -ve

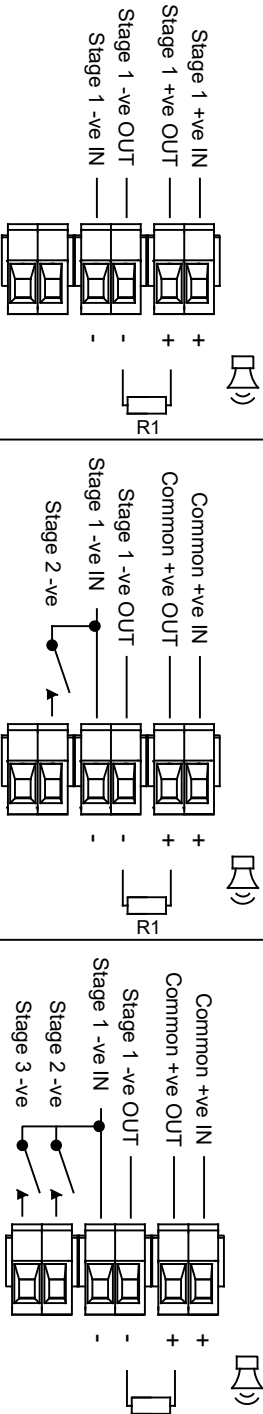

D	Stage 1 +ve IN Stage 1 +ve OUT Stage 1 -ve OUT Stage 1 -ve IN	+	+	+	+
E					
F					

DRAWING TO BE RELEASED TO ISO 11011:1983 ANGLS 4 DIMENSIONAL TOOLS		DRAWN	DATE	SURFACE FINISH	WEIGHT (KG)	THIS DRAWING AND ANY INFORMATION OR DESCRIPTION MATTER HEREIN IS UNCLASSIFIED IN COMPLIANCE WITH SYSTEMS TO MEET THE HOLDS OR ANY EXTRINSIC MAY MANUFACTURING OR TENDERS PURPOSES WITHOUT THEIR WRITTEN CONSENT. BIRCHFIELD GROUP LTD. AS PER LATEST DATE OF ISSUE SHOWN ABOVE		ALL DIMENSIONS IN MM IF IN QUOTE ASK - DON'T SCALE		A3
STANDARDS		CHECKED	DATE					TITLE A100, A105N & D105 DC SOUNDER WIRING DIAGRAMS		
ALERT/LARM RANGE		APPROVED	DATE					SCALE	SHEET	DRAWING NUMBER
		R.N.POTTS	16/03/2021					NTS	1 OF 1	D218-06-001





Single Stage Configuration

Stage 1: Apply Power to Stage 1 Live & Stage 1 Neutral

Three/Four Stage Configuration

Stage 1: Apply Power to Stage 1 Live & Stage 1 Neutral  
 Stage 2: Apply Power to Stage 1 Live & Stage 1 Neutral  
 & connect Stage 2 to Live  
 Stage 3: Apply Power to Stage 1 Live & Stage 1 Neutral  
 & connect Stage 3 to Live  
 Stage 4: Apply Power to Stage 1 Live & Stage 1 Neutral  
 & connect both Stage 2 & Stage 3 to Live

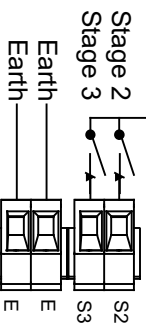
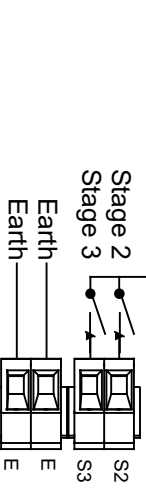
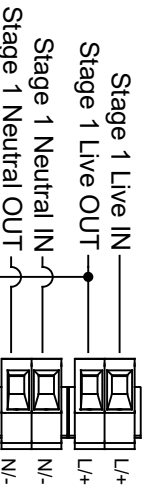
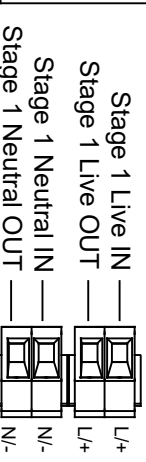
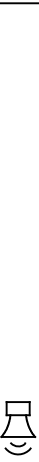
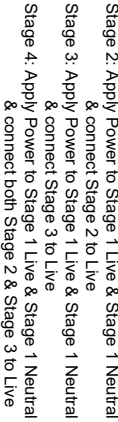
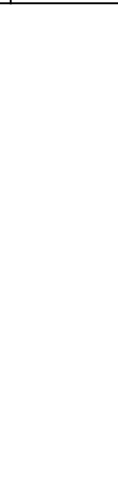

DRAWING TO BS 6888:2000  
 GEOMETRIC TOLERANCES TO ISO 1101:1983  
 ANGLE DIMENSIONAL TOLS  
 SURFACE FINISH

DRAWN	DATE	SURFACE FINISH	WEIGHT (KG)
R.S. RAIT	16/03/2021		
CHECKED	DATE	MATERIAL	
B. ISARD	16/03/2021		
APPROVED	DATE	ALTERNATIVE MATERIAL	
R.N.POTTS	16/03/2021		

THIS DRAWING AND ANY INFORMATION OR DESCRIPTIVE  
 MATTER HEREIN IS UNMAYNED IN CONNECTION WITH  
 THE SYSTEMS AND EQUIPMENT WHICH IT RELATES TO AND  
 IS NOT TO BE USED FOR ANY OTHER PURPOSES WITHOUT THE  
 WRITTEN CONSENT OF THE MANUFACTURER OR  
 SUPPLIER OF THE SYSTEMS AND EQUIPMENT.  
 REPORT DATE: 16/03/2021  
 AS PER LATEST DATE OF ISSUE SHOWN ABOVE

ALL DIMENSIONS IN MM IF IN QUOTE, ASK DON'T SCALE		A3
TITLE A100, A105N & D105 AC WIRING DIAGRAMS		

STANDARDS	ALERT/ALARM RANGE	SCALE	SHEET	DRAWING NUMBER
		NTS	1 OF 1	D218-06-005





